



IMPORTANT: Read These Operating and Safety Instructions Before Using the Inductor®.

OPERATING AND SAFETY INSTRUCTIONS

Specializing in High Performance Induction Heating Systems for the Automotive Aftermarket



TM

INDUCTION INNOVATIONS

**Induction Innovations, Inc.
1175 Jansen Farm Court
Elgin, IL 60123
www.theINDUCTOR.com**

**Toll Free 877-688-9633
Local 847-836-6933
Fax 847-551-3369
Info@theinductor.com**

Table of Contents

	Page
I. Safety Rules.....	3-6
A. . General Work Area Safety Rules.....	3
B. Personal Safety Rules	4
C. Electrical Safety Rules	4-5
D. Fire Hazard Safety Rules	5-6
E. Tool Use Safety Rules	6
II. Components.....	7-10
A. Inductor® Pro Max™ Components	7
B. Inductor® Max™ Components	8
C. Inductor® Attachments.....	9
D. Inductor® Glass Blaster® Components	10
III. Principles of Operation.....	11
IV. Preparation for Use.....	11-12
A. Generator & Inverter Use.....	11
1. Generator.....	11
2. Inverter	11
3. Steps 1 through 10	11-12
V. Using the Glass Blaster®	13
A. Removing a Complete Window When the Position of the Urethane Seal is known	13-14
B. “Stubborn” Glass That Won’t Release from the Pinch Weld	14-15
C. Removing SMC-bonded Roofs and Other Trim.....	15-16
VI. Using the Fast Off	16-17
A. Removing Decals, Vinyl Graphics, and Pin Striping	16
B. Removing Body Side Moldings.....	17
C. Warming Cold Body Panels.....	17
VII. Using the Concentrator.....	17-18
A. Loosening Corroded, Rusted and “Frozen” Nuts and Bolts	17-18
B. Removing Caulking Strips.....	18
C. Heat Shrinking Hail Dents in Sheet Metal.....	18
VIII. Using the Rosebud.....	18-19
A. Frame Rail Straightening	18-19
B. Aluminum Annealing.....	19
IX. Troubleshooting.....	19
X. Disassembly & Storage	19
XI. Cleaning Instructions.....	20
XII. Warranty & Repairs.....	20
XIII. Definitions	21-22
XIV. Additional Training	22

I. Safety Rules for Using the Inductor®

A. General Work Area Safety Rules

WARNING



Read and understand all instructions. Failure to follow all instructions listed below may result in electric shock, fire, and/or serious personal injury.

WARNING

Keep your work area clean and well illuminated. Cluttered and dark areas invite accidents.

WARNING

Keep bystanders, children, visitors and animals away while operating the Inductor®. These beings may create distractions that cause you to lose control of the Inductor®.

WARNING

Work outdoors, if there is no danger of rain, water or moisture. If this is not possible, keep the inside work area well ventilated and dry. Be sure that ventilation fans are moving air from the inside to the outside.

CAUTION

Keep a fully charged fire extinguisher at hand at all times when using the Inductor®.

B. Personal Safety Rules

DANGER



Do not operate the Inductor®, and stay at least twenty feet away from an operating Inductor®, if you have a cardiac pacemaker or any other kind of electronic or surgical implant. The Inductor® will interfere with the operation of cardiac pacemakers and other implanted electronic medical devices, and can cause dangerous heating of any metal items in your body, for example, artificial joints and bone screws and braces.

WARNING



Do not operate the Inductor® while wearing any metallic items such as jewelry, rings, watches, chains, identification tags, religious medals, belt buckles, body piercing hardware, etc. The Inductor® can heat these metallic objects very quickly and cause serious burns or even ignite clothing.

WARNING

Do not operate the Inductor® while under the influence of drugs, alcohol or any medication.

WARNING

Do not overreach, keep proper footing and balance at all times. Proper footing and balance enables better control of the Inductor® in unexpected situations.

WARNING

Do not use the Inductor® within 4 inches of any airbag component. The heat created from the Inductor® can ignite the air bag propellant, causing it to explode without warning. Refer to the vehicles service manual for precise airbag location before operating.

Personal Safety Rules Continued

WARNING



Remove all loose coins, metallic tokens, keys, chains, pocket knives, miniature tools, or any other metallic object in or on your clothing before operating the Inductor®. Do not replace these items until you are finished using the Inductor®. The Inductor® can heat these metallic objects very quickly and cause serious burns or even ignite clothing.

WARNING



Do not wear clothing that is made with metallic pocket rivets, waist band buttons, pocket buttons, and zippers when operating the Inductor®. The Inductor® can heat such metallic items very quickly and cause serious burns or even ignite clothing.

WARNING

Do not operate the Inductor® while under the influence of drugs, alcohol or any medication.

WARNING



Always wear safety goggles when using the Inductor®.

WARNING



Fumes and smoke from hot/burning adhesives are toxic. Wear a dual filter (dust and fume) respirator mask which has been approved by the Occupational Safety and Health Administration (OSHA), the National Institute of Safety and Health (NIOSH), or the United States Bureau of Mines. These masks and replaceable filters are readily available at major hardware stores. Be sure the mask fits. Beards and facial hair may keep masks from sealing properly. Change filters often. DISPOSABLE PAPER MASKS ARE NOT ADEQUATE.

WARNING



Wear heat-resistant gloves when using the Inductor®. The Inductor® heats metal very quickly. You can burn your hands and fingers when trying to remove parts from hot metal surfaces.

C. Electrical Safety Rules

⚠ DANGER



Do not use the Inductor® in the rain, moisture or immerse in water. Exposing the Inductor® to water or other liquids may cause an electrical shock hazard.

Electrical Safety Rules Continued

⚠ DANGER



When operating the Inductor®, always test the Ground Fault Interrupter (GFI) to make sure that it is working properly. To test the GFI, connect the plug to a power source. Push the test button on the GFI—you will hear a “click” and the button will pop out from the body of the GFI. Step on the pneumatic foot switch— it should not beep, indicating that the Inductor® cannot be turned ON. To restore normal operation, push the RESET button on the GFI until it clicks and make sure that it remains in the depressed position. If the GFI fails the preceding test, do NOT use the Inductor®. Contact Induction Innovations, Inc. at 877-688-9633.

⚠ WARNING



Do not abuse the electrical cords. Never use the cords to carry the Inductor® or its attachments. Keep the cords away from heat, oil, sharp edges and/or moving parts. Do not use the Inductor® if the cords are damaged. Cords cannot be repaired, only replaced. Damaged cords create electric shock hazards.

⚠ WARNING



Disconnect the Inductor® from the power supply cord before changing any of the applicators.

⚠ CAUTION



Unplug the Inductor® from the power supply outlet or cord when not in use.

⚠ CAUTION



Do not use the Inductor® if the pneumatic foot switch does not turn the unit ON or OFF.

⚠ CAUTION



EXTENSION CORDS:

If an extension cord is necessary, only the following two cord lengths are authorized for use with the Inductor®:

25 foot, 14-AWG;

50-ft, 12-AWG.

- Use only one extension cord at any one time.
- Do not connect two or more extension cords in series with each other.
- Do not use any other extension cords except those specified above. Unwrap extension cords — tightly wrapped extension cords can overheat and cause fires.

D. Fire Hazard Safety Rules

⚠ DANGER



Do not attempt to heat aerosol cans, paint cans, or any pressurized containers used for storing fuels, compressed gases, and liquids. The heat generated by the Inductor® can cause these containers to explode and their contents to ignite.

Fire Hazard Safety Rules Continued

⚠ WARNING



Interior trim pieces and headliners may be damaged or ignited by the heat created by the Inductor® when removing glass. The ignition of these materials may not be readily apparent and could result in property damage and injury to persons. When removing windshields and other glass, keep the Inductor® applicator tool moving in a back-and-forth motion along with outward pressure. Lingering or pausing in one spot could ignite interior trim and/or headliners.

⚠ CAUTION



Do not store miscellaneous items such as rags, cloths, bags, etc. in the Inductor® storage case. Such items may obstruct the cooling air flow to the Power Unit and cause overheating and a fire hazard.

E. Tool Use Safety Rules

⚠ WARNING



Do not leave the Inductor® unattended when it is ON.

⚠ WARNING



Make sure that the Power Unit has a sufficient supply of air for cooling. Do not operate the Inductor® with the top of the storage case closed or partially open. Make sure that the vents of the Inductor® Power Unit are clean and free of dust and debris so that the Power Unit has an unimpeded flow of cooling air.

⚠ CAUTION

Do not defeat the function of the pneumatic foot switch.

⚠ CAUTION

Do not attempt to repair or service the Inductor®. There are no user-serviceable parts except for renewing the heat barriers on the Concentrator™ and Rosebud™.

⚠ CAUTION

Before plugging in the Inductor®, make sure that the outlet voltage supplied is compatible with the voltage marked on the nameplate within 10%. An outlet voltage incompatible with that specified on the nameplate can result in serious hazards and damage to the Inductor®.

⚠ CAUTION

Do not separate the attachment cord connectors from the Inductor® cord connector by yanking or pulling on the cords to disengage the connectors. If the Inductor® is operating when the connectors are separated, NON-WARRANTABLE damage to the internal electronics of the Inductor® may occur.

⚠ CAUTION

Do not twist or bend electrical cords sharply, or damage to internal wiring will result.

II. Components

A. Inductor® Pro Max™ Components

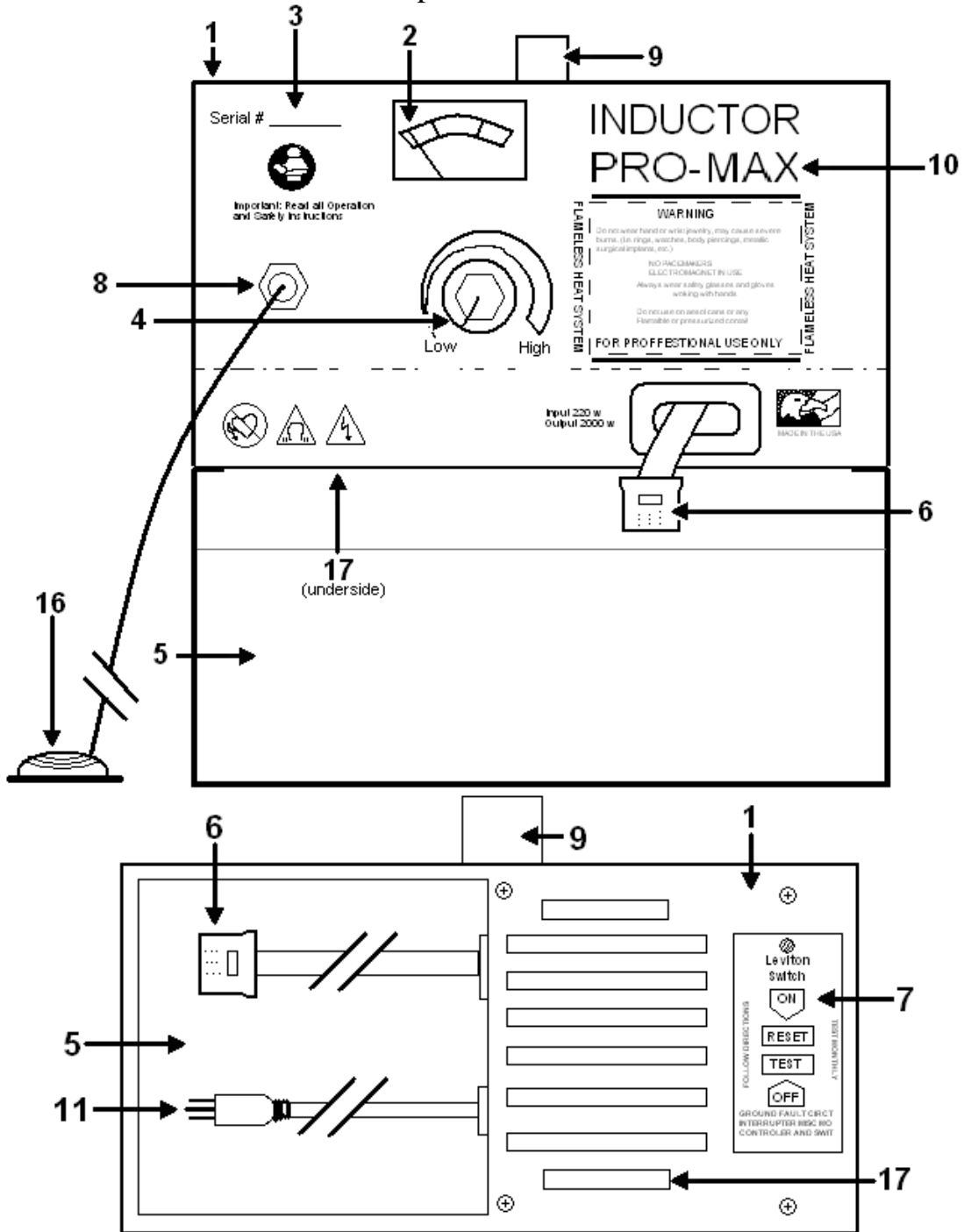

- | | |
|-----------------------------------|---|
| 1. Inverter | 10. Model |
| 2. Power Level Meter | 11. Plug 110/120 AC |
| 3. Serial Plate | 12. Glass Blaster® Attachment |
| 4. Power Control Knob | 13. Fast Off Attachment |
| 5. Storage case | 14. Concentrator Attachment |
| 6. HF Female Output Connector | 15. Rosebud Attachment |
| 7. GFI (Ground Fault Interrupter) | 16. Pneumatic Foot Switch with air hose |
| 8. Barb Hose Fitting | 17. Vent |
| 9. Handle | 18. Instructional DVD (Not Shown) |

19. Owners Manual (Not Shown)
 B. Inductor® Max™ Components

20. I-wedge (Not Shown)

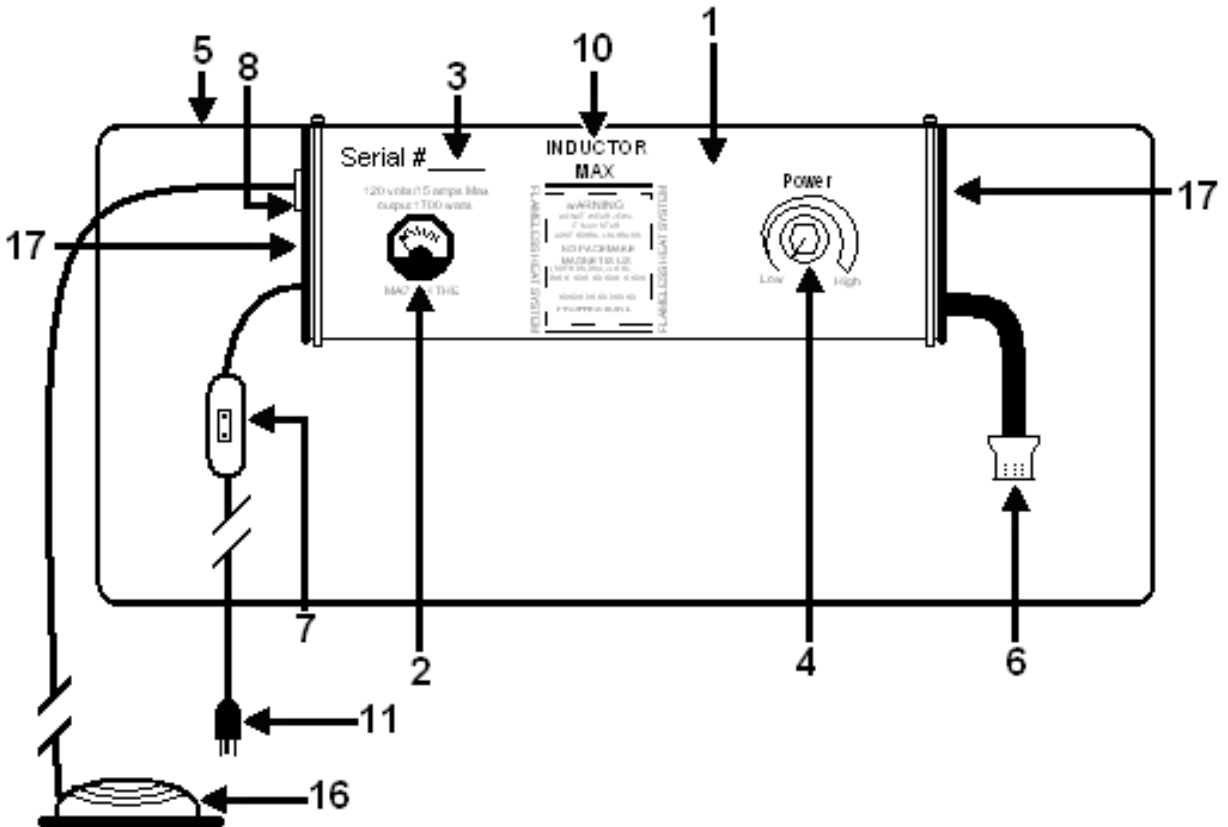

- | | |
|-----------------------------------|---|
| 1. Inverter | 11. Plug 110/120 AC |
| 2. Power Level Meter | 12. Glass Blaster® Attachment |
| 3. Serial Plate | 13. Fast Off Attachment |
| 4. Power Control Knob | 14. Concentrator Attachment |
| 5. Storage case | 15. Rosebud Attachment |
| 6. HF Female Output Connector | 16. Pneumatic Foot Switch with air hose |
| 7. GFI (Ground Fault Interrupter) | 17. Vent |
| 8. Barb Hose Fitting | 18. Instructional DVD (Not Shown) |
| 9. Handle (Not Shown) | 19. Owners Manual (Not Shown) |
| 10. Model | 20. I-wedge (Not Shown) |

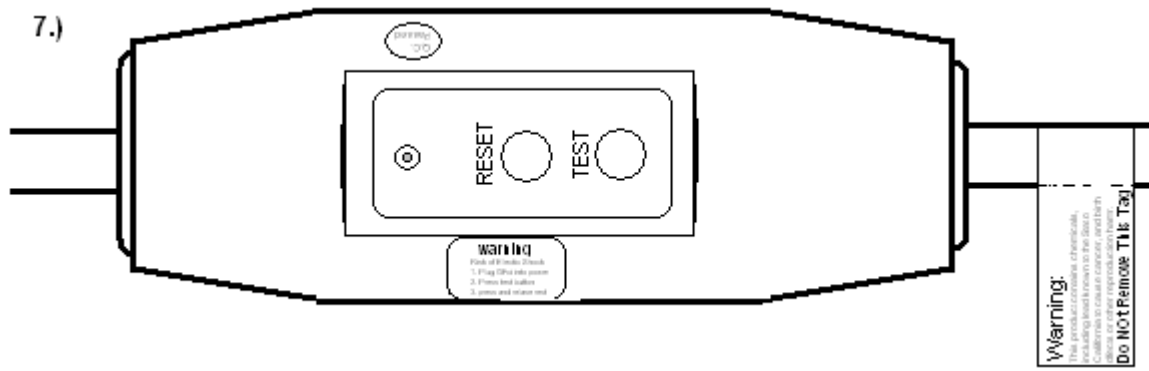

Inductor® Attachments

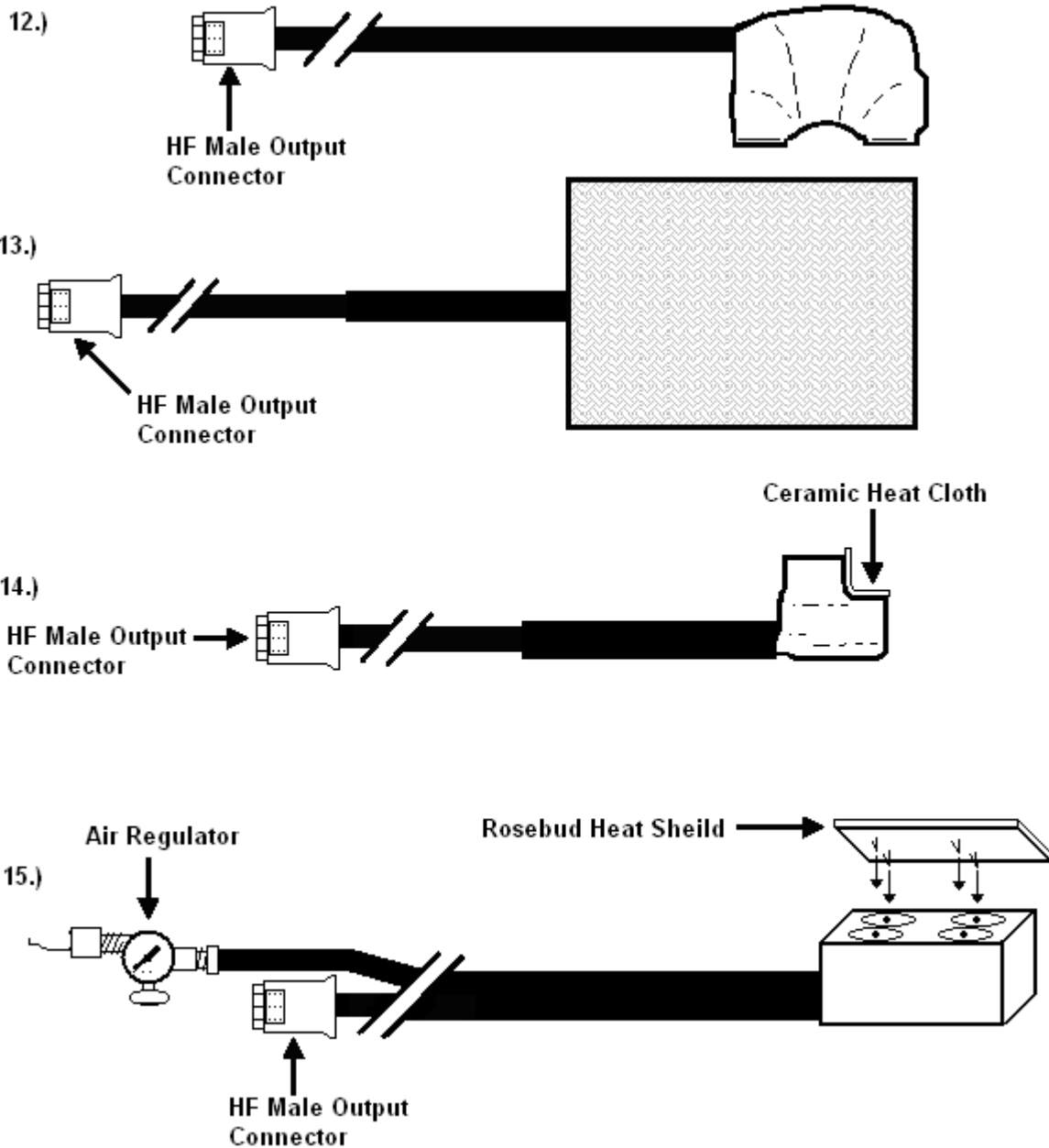

- | | |
|-----------------------------------|---|
| 1) Inverter | 11) Plug 110/120 AC |
| 2) Power Level Meter | 12) Glass Blaster® Attachment |
| 3) Serial Plate | 13) Fast Off Attachment |
| 4) Power Control Knob | 14) Concentrator Attachment |
| 5) Storage case | 15) Rosebud Attachment |
| 6) HF Female Output Connector | 16) Pneumatic Foot Switch with air hose |
| 7) GFI (Ground Fault Interrupter) | 17) Vent |
| 8) Barb Hose Fitting | 18) Instructional DVD (Not Shown) |
| 9) Handle | 19) Owners Manual (Not Shown) |
| 10) Model | 20) I-wedge (Not Shown) |

C. Inductor® Glass Blaster® Components

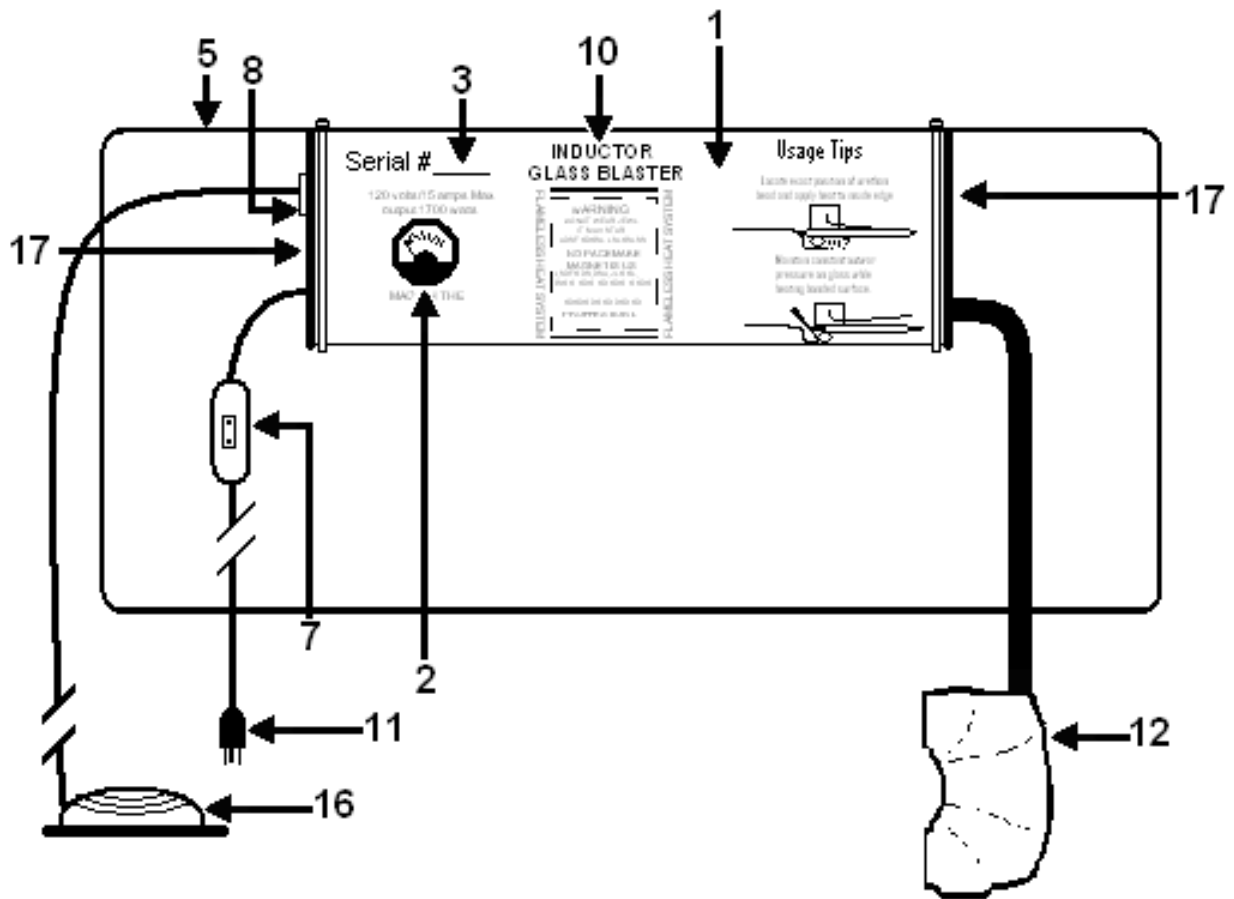

- | | |
|---|---|
| 1. Inverter | 10. Model |
| 2. Power Level Meter | 11. Plug 110/120 AC |
| 3. Serial Plate | 12. Glass Blaster® Attachment |
| 4. Power Control Knob
(Not with Glass Blaster) | 13. Fast Off Attachment |
| 5. Storage case | 14. Concentrator Attachment |
| 6. HF Female Output Connector
(Not with Glass Blaster) | 15. Rosebud Attachment |
| 7. GFI (Ground Fault Interrupter) | 16. Pneumatic Foot Switch with air hose |
| 8. Barb Hose Fitting | 17. Vent |
| 9. Handle (Not Shown) | 18. Instructional DVD (Not Shown) |
| | 19. Owners Manual (Not Shown) |
| | 20. I-wedge (Not Shown) |

(Refer to the illustrations on this and preceding pages, as necessary. Numbers in parentheses in the text following refer to callouts on the illustrations.)

III. PRINCIPLES OF OPERATION

The **GFI** (7) and **power cord** (11) insures a properly grounded 120 VAC power input connection. The **inverter** (1) steps up ordinary 120 volt, 60 Hz alternating line current to a high Frequency, which the tool – **Glass Blaster®** (12), **Fast Off®** (13), **Concentrator®** (14), or **Rosebud™** (15) – converts to a high frequency alternating magnetic field. This magnetic field crosses the metallic, conductive work surface (e. g., the sheet metal of an automobile body panel) and vibrates the electrons in the metal through the principle of electromagnetic induction. The kinetic energy of the moving electrons is dissipated as heat, which warms whatever metal is within the tool’s working range (about 1-1/2 inches). The more easily magnetized a substance is, the greater the heat developed in it. That is why the Inductor® heats ferrous metals and their alloys readily, but has no effect on glass, plastics, wood, cloth and other non-conductive materials. The inverter is equipped with a **meter** (2), which indicates the relative amount of power that is being delivered to the attachment and, indirectly, the amount of heat created. The meter is color coded with green, yellow and red ranges, indicating, respectively, low, medium and high power generation. The meter may also be used to locate hidden metal such as a pinch weld when removing a window. The inverter may also have a **power control knob** (4) to adjust the level of power being delivered to the attachment. Turning the power control knob clockwise increases the power, turning it counterclockwise decreases the power. The **pneumatic foot switch** (16) is used to turn the inverter on and off. Step or squeeze it to turn on power to the unit. The unit will remain ON as long as pressure is applied to the switch. Remove pressure from the switch to turn the power OFF. Refer to the **serial number plate** (3) on the inverter and record the serial number on the enclosed Warranty Card for use when making a warranty claim.

IV. PREPARATION FOR USE

⚠ WARNING



Read and understand all safety warnings and cautions in this manual before operating the Inductor®.

A. Generator & Inverter Use

⚠ CAUTION

The Inductor® is designed to operate from a normal 120 volt alternating current (VAC), 50 or 60 Hz (cycles per second) power line or service outlet, and will operate without suffering damage on voltages up to 130 VAC.

1. Generator: Some portable generators, particularly low-cost units producing 4 kW or less, are unregulated and can produce in excess of 140 VAC which will damage the unit and void the warranty. If you are in doubt concerning the electrical generator that will be supplying power to the Inductor®, have a professional electrical contractor measure the generator voltage with a digital voltmeter. Measure the voltage with the generator engine warm and no load. Some generators, the voltage may be reduced by decreasing the engine speed.
2. Inverter: DC to AC Inverter operation; Use only 1.8 kW (Prosine™1800 is recommended*) or larger sine wave inverter. The use of square or quasi-sine wave inverter will void the warranty. Call Induction Innovations, Inc. at 877-688-9633, before using your Inductor® for instructions on how to proceed if you have any questions regarding the instructions furnished above.

Step 1 Remove the pneumatic foot switch and its attached air -line. Make sure that the air line is inserted fully on the hose barb fitting on the inverter and that the retaining nut on the fitting is tightened.

Step 2 Remove the attachment that you intend to use.

Step 3 Remove the power cord.

Step 4 Remove the tool cord with its integral female connector.

Step 5 Make sure that any items stored in the case are not blocking the inverter vents for cooling air.

Step 6 Make sure that the power control knob is turned fully counterclockwise to “Low.”

Step 7 Connect the power plug to a service outlet or extension cord.

Step 8 Test the GFI (7) for proper functioning by pushing the button labeled “TEST”: the reset button should pop out and you should hear a click.

⚠ DANGER



To reduce the risk of electric shock do not remove, modify, or immerse the GFI.

Perform the GFI test every time that you prepare the Inductor® for use. If the GFI fails this test, do NOT use the unit. Call Induction Innovations, Inc. at 877-688-9633 for instructions on how to return the unit for repair.

Step 8 If the GFI passes its test; connect the tool to the tool power cord and connector. (See diagram below) Align the brass straps on each of the multi-contact connectors and press them together gently until the two latches engage fully with a “click.”

Right Way

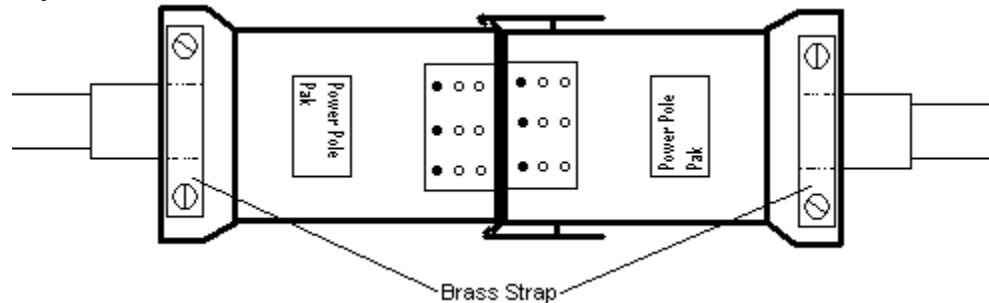

Wrong Way

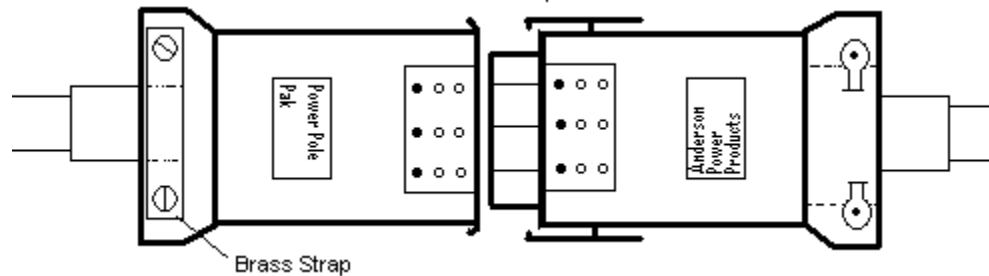

Step 9 Hold the applicator head of the tool away from metallic objects.

Step 10 Step on the foot switch to see if the inverter will turn ON. If it does, you will hear a continuous beeping sound from the inverter. Release the foot switch to turn the power OFF while you position yourself and the tool for work. If the inverter will not turn ON and OFF when the foot switch is pressed and released, do NOT use the unit. Call the Technical Services Department of Induction Innovations, Inc. at **877-688-9633** for instructions on how to return the unit for repair. 14. If you have observed all the *Safety Rules* of this manual, you are now ready to begin using the **Inductor®**. If you have not read and followed all the Safety Rules, **DO SO NOW** before using the unit. If there is anything in these Instructions that you do not understand completely, **DO NOT ATTEMPT TO USE** the Inductor®. Call Induction Innovations, Inc. at **877-688-9633** for instructions on how to proceed.

V. USING THE GLASS BLASTER®

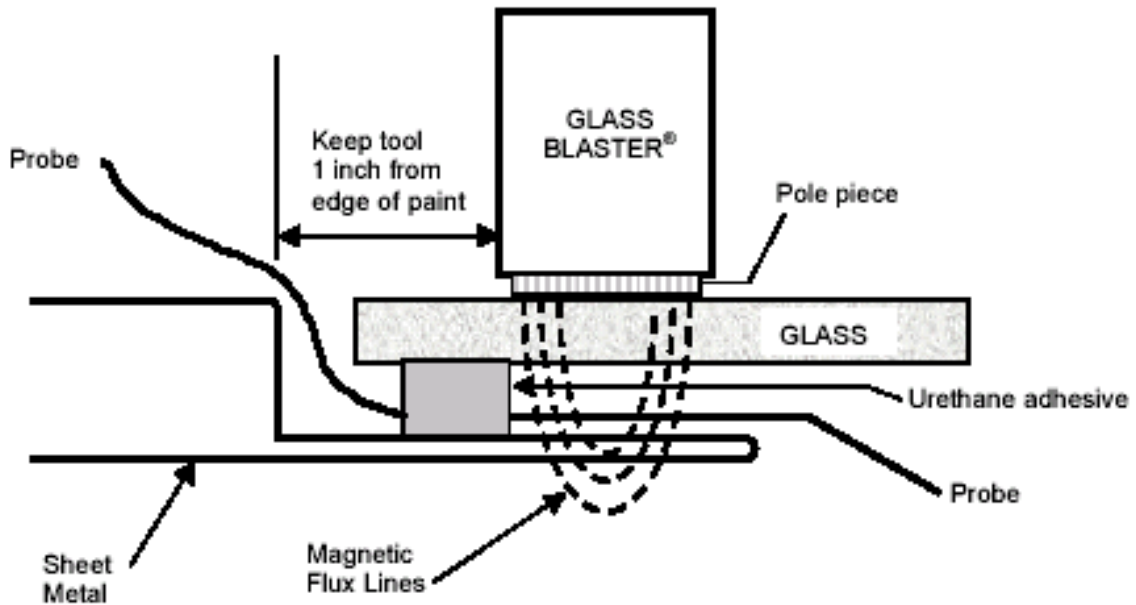

Functions: The *Glass Blaster®* (12) tool (shown above) is formed in the shape of a shallow upside down U, and the magnetic lines of flux pass back and forth in an arc between the pole pieces (the two flat square surfaces at the open end points of the U). The Glass Blaster® tool heats metal at high intensity in the shape of an oval or ellipse centered on the long axis of the tool, which makes it ideal for the quick, easy and clean removal of automotive glass, bonded SMC Panels, Bed liner, metal bond adhesives, etc.

Tip: Practice on a junk car or clip in order to master the techniques of using the Glass Blaster® before attempting to work on a customer's car. Windshields are laminated glass and very fragile. Practice first on the less fragile tempered glass from rear hatches and rear windows. The most important thing to remember when using any of the Inductor® tools is that it's far better to use too little heat at first, and take a few more minutes on the job to gain the experience necessary to use the tool well, than to use too much heat and burn the paint, ignite the headliner, or damage any trim.

A. Removing a Complete Window When the Position of the Urethane Seal is known

Step 1 Remove any metallic trim or reveal molding, if applicable.

Step 2 Pull back any non-metallic trim or reveal moldings, if present.

Step 3 If you are unfamiliar with the particular model vehicle and where the urethane adhesive seal is relative to the edge of the window glass, use your I-wedge, to probe for the location of the urethane adhesive. Mark the location of the urethane adhesive (refer to illustration above) on the glass to assist in placing the Glass Blaster® for best performance. The ideal placement of the Glass Blaster® tool is just inside the edge of the urethane adhesive, but never closer than at least one inch from the edge of the glass, to avoid burning the good paint.

Step 4 Turn the power control knob on the inverter all the way clockwise to Full (Maximum) power (also labeled as the "Glass Blaster®" setting) but do NOT turn ON the Inductor® yet.

Tip: The best place to start on most glass is at a corner. Pick a corner that is accessible from the inside and the outside of the vehicle, so that you can

*apply outward pressure on the glass to break the urethane bond after heat has been applied to the pinch weld by the **Glass Blaster®** tool.*

Step 5 Position the Glass Blaster® tool on the glass near a corner, with the two flat pole piece surfaces on the glass, and with its long axis aligned with the inside edge of the urethane adhesive that you have measured already. Use a marking tool to make some guide lines if they will help you keep the Glass Blaster® tool at the inside edge of the urethane adhesive.

Step 6 Step on the foot switch to turn the power ON. Immediately begin to move the Glass Blaster® tool parallel to the horizontal or vertical side of the corner, at a rate of 1/2-inch per second, for a distance of 9 inches from the corner outward, and then back into the corner, as shown in the illustration to the right. When you reach the corner, turn the Glass Blaster® tool and move it at the same rate of 1/2-inch per second 9 inches down the other side of the corner, and back to the corner. Release the foot switch to turn the power OFF.

 **WARNING**



There may be a light trail of smoke from inside the car, as the urethane heats up and begins to soften; this is quite usual and not a cause for concern. If the smoke is heavy, black and dense, the Glass Blaster® tool maybe too close to the edge of the glass and is heating the sheet metal pinch weld too hot. This can result in a FIRE HAZARD!

Step 7 Using the provided I-wedge; gently pry up on the corner of the glass while simultaneously pushing outward on the glass. If the adhesive is reluctant to come free of the pinch weld, turn the Inductor® ON and place one pole piece of the Glass Blaster® tool over the area where you are prying, to get a little extra heat. When the adhesive bond yields, you will hear a “popping” or “ripping” sound and see the glass lift a fraction of an inch. Release pressure from the pneumatic foot switch to turn the power OFF, remove the Glass Blaster® tool from the glass, and gently insert an I-wedge into the gap between the glass and the pinch weld.

Step 8 Place the Glass Blaster® tool back on the glass, parallel to an edge, at the distance determined by probing for the adhesive. Apply pressure to the pneumatic foot switch to turn the power ON again and work back and forth one time over 9 inches at 1/2-inch per second. Release the foot switch to turn the power OFF, set the Glass Blaster® tool aside, and gently insert another I-wedge to release the urethane adhesive bond.

Tip: Try stacking the I-wedges two high, if necessary, to maintain sufficient outward pressure on the glass.

Step 9 Continue to work around the remainder of the window in this manner until the entire glass is free. After previously released areas have cooled the I-wedges are not needed in these locations any longer and they can be removed and reused to the areas where heat is being actively applied to release the urethane adhesive.

B. “Stubborn” Glass That Won’t Release from the Pinch weld

Step 1 If you have been following carefully the techniques described in Section A above, but a particular piece of glass just won’t de-adhere from the pinch weld, even though you went too close to the edge of the glass and caused a lot of smoke and perhaps came very close to burning the paint, this may be due to a narrow pinch weld that is not heating up well, or a previous window replacement where the application of adhesive was too heavy.

Step 2 If the unit is not OFF; release the foot switch to turn the power OFF.

Step 3 Disconnect the plug from the service outlet or extension cord.

Step 4 (Refer to the illustration below) Soak a bath towel or similar piece of fabric, in water and wring it out so that it is damp, but not dripping. Roll or fold the towel up the long way and place it on the sheet metal along the length where the glass won't release from the pinch weld. Shape the towel to cover the paint next to the length of glass on which you are working. The damp towel will act as a heat sink to keep the adjacent painted metal cool. A welding paste or thermal gel may be used in place of a damp towel.

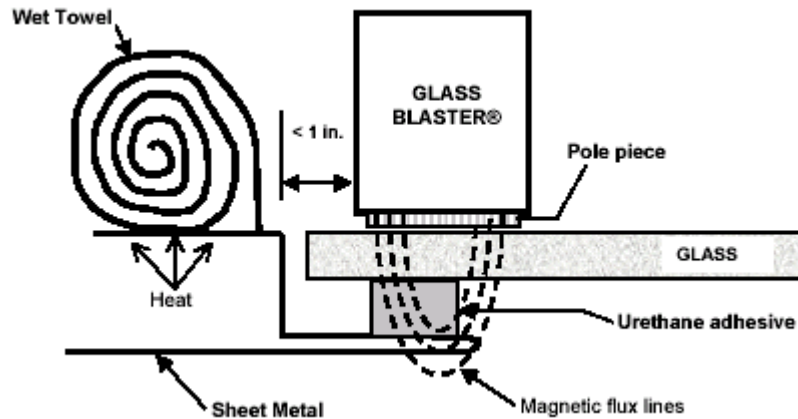

Step 5 With a dry towel, wipe up any water that has trickled down the glass. Be sure that water is not dripping from the wet towel.

Step 6 Connect the plug to the service outlet or extension cord. Test the GFI by pushing the test button on the plug: the reset button on the GFI should pop out and you should hear a click. If the GFI fails this test, do NOT use the unit. Call Induction Innovations, Inc. at **877-688-9633** for instructions on how to return the unit for repair.

Step 7 Make sure that the power control knob, if applicable, is turned clockwise to the maximum position.

Step 8 Position the Glass Blaster® tool on the glass at the problem area.

Step 9 Step on the foot switch to turn the power ON and continue moving the Glass Blaster® tool back and forth at 1/2-inch per second to loosen the glass from the pinch weld. With the wet towel in place, you can move the Glass Blaster® tool closer to the edge of the glass without risking damage to the visible paint.

Step 10 After the glass has been removed, release the foot switch to turn the power OFF and set the Glass Blaster® tool down in a secure place.

Step 11 Turn the power control knob fully counterclockwise to Low, if applicable.

Step 12 Disconnect the plug from the service outlet or extension cord.

Step 13 Remove the wet towel, welding paste or thermal gel and dry any moist areas if further work is to be performed on the vehicle.

C. Removing SMC-bonded Roofs and Other Appliqué's

Step 1 Cover the poles of the Glass Blaster® tool with a light cloth to avoid scratching the plastic panels.

Step 2 Follow the steps in "Preparation for Use," and set the power control knob to the "Max/Glass Blaster" setting.

Step 3 Apply outward pressure on panel to be removed while placing the glass blaster® over the adhered area. If adhered area is not known, apply pressure

and look for slight shallow dimples on panel, this is where adhesive remains adhered.

Step 4 Step on the foot switch to turn the power ON and move the Glass Blaster® tool in a back-and-forth or circular motion over a 4-5 inch radius over the lowest dimple on one side of the panel; the glue spots are often several inches in diameter.

Step 5 Pry gently outward with an I-wedge until the adhesive releases the panel.

Step 6 Be sure to check frequently that the plastic surface does not become too hot.

Step 7 Use the I-wedge to apply constant outward pressure to the panel in the same way that used in glass removal.

VI. USING THE FAST OFF®

Function: The *Fast Off*® (13) is arranged so that the flux lines are spread out evenly over the entire surface of the pad, in order to achieve a less intense, more evenly distributed heat in the metal to which it is applied. While not as strong a heat producer as the **Glass Blaster**® or **Concentrator**®, or **Rosebud**™, the **Fast Off**® will still burn paint in a very short time if used carelessly. The **Fast Off**® is designed for the removal of body side moldings, stripes, vinyl graphics, emblems, and other self-adhesive trim pieces without damage. It can also be flexed to wrap around circular objects (i.e. bearing housing)

A. Removing Decals, Vinyl Graphics, and Striping

Step 1 Perform the “Preparation for Use” instructions on pages 12 - 15.

Step 2 Begin with a power setting midway between the “Low” and “Max” settings. Make adjustments to the power setting after you see how much power the work actually requires.

Step 3 Step on the pneumatic foot switch to turn the power ON.

Step 4 Move the Fast Off® in a slow circular or back-and forth motion over one end of a stripe or linear molding, or over a portion of the edge of a decal or graphic. Be sure to keep the Fast Off® pad parallel to the surface on which the trim item is applied.

Step 5 After a few seconds, using an I-wedge, try to lift an edge or portion of the item to be removed. If it lifts easily, keep upward tension on the item and move the Fast Off® a bit further on, maintaining the circular or reciprocating motion. If the item does not lift easily, apply heat for another a few seconds longer, carefully observing any signs of distress in the paint, then try lifting the item again.

Step 6 Repeat these actions until the item is entirely removed.

Step 7 Release the pneumatic foot switch to turn the power OFF. NOTE: Be careful not to overheat vinyl graphics, as they will become too soft to handle and lift up without compromising their integrity and making a mess. If they seem to be in this state when you try to lift them, release the foot switch to turn the power OFF, and let the graphics cool for a minute before trying again to remove them.

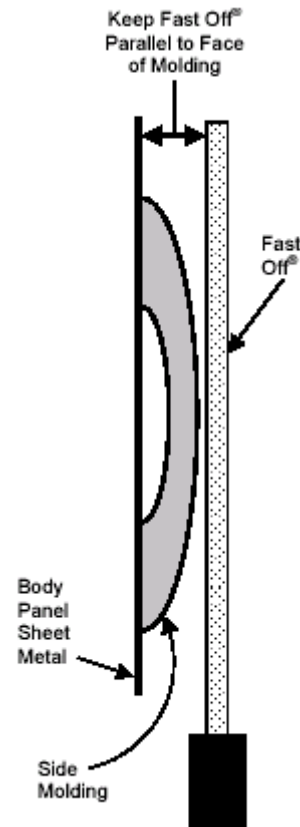

B. Removing Body Side Moldings

Step 1 Perform the “Preparation for Use” instructions on pp 12-15.

Step 2 Set the power control knob to medium power, halfway between the “Low” and “Max” settings — this is the best setting at which to begin. For thicker moldings, you can start at a higher power level, but until you are experienced, start at the halfway level until you determine precisely what power level is best for which type of molding.

Step 3 Using you I-wedge, begin to lift molding applying outward pressure on molding.

Step 4 Step on the pneumatic foot switch to turn the power ON.

Step 5 Move the Fast Off® in a slow back-and-forth motion over one end of a molding. Be sure to keep the Fast Off® pad parallel to the surface on which the trim item is applied. If the molding lifts easily, keep outward tension on the item and move the Fast Off® a bit further on, maintaining the reciprocating motion. If the item does not lift easily, apply heat for another few seconds, carefully observing any signs of stress in the paint, then try lifting the item again.

Step 6 Repeat these actions until the item is entirely removed.

Step 7 Release the foot switch to turn the power OFF.

C. Warming Cold Body Panels

1. During cold weather, the Fast Off® pad can be used to warm cold body panels to room temperature so that trim adhesives will stick to them.

VII. USING THE CONCENTRATOR®

Function: The **Concentrator®** (13) is used to heat nuts, fasteners, hail dent heat shrinking, caulking removal, frozen door hinges, etc.

CAUTION



The Concentrator® must **NEVER** be used without the heat-resistant ceramic cloth shown in the illustration on the facing page, because the heat generated in the parts being worked on is sufficient to damage the magnetic ferrite material in the pole pieces.

A. Loosening Corroded, Rusted and “Frozen” Nuts and Bolts

Step 1 Perform the “Preparation for Use” instructions.

Step 2 Set the power control knob fully clockwise to the “Max” setting.

Step 3 Step on the pneumatic foot switch to turn the power ON.

Step 4 Bring the Concentrator® towards the frozen nut, keeping a minimum distance of 1/16 inch between the ceramic cloth of the Concentrator® and the nut at all times. Initially, bring the Concentrator® close to the nut for only two seconds, back it away, and try to remove the nut with a wrench or socket. If it is still frozen, apply the Concentrator® for another two seconds, and then try

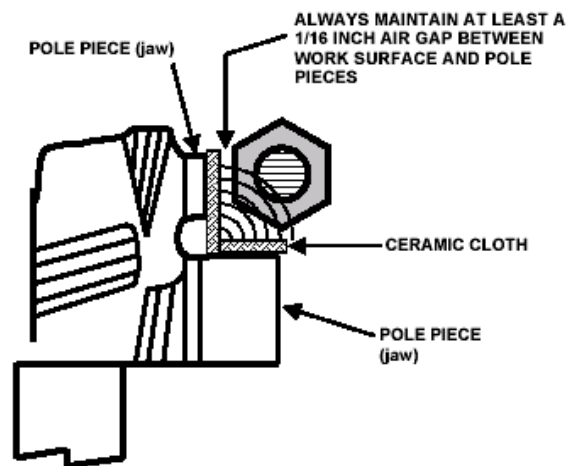

the wrench again. There is usually no reason to heat a nut to a red-hot condition in order to free it from the corrosion holding it to the bolt.

B. Removing Caulking Strips

1. Steps 1 through

Step 1 Perform the “Preparation for Use” instructions.

Step 2 Set the power control knob to halfway between the “Low” and “Max” settings.

Step 3 Step on the foot switch to turn the power ON.

Step 4 Start by heating one end of the caulking strip for 2-3 seconds, and then dig out the caulking with a putty knife or similar tool. Slowly work the Concentrator® down the length of the strip, digging out the hot, soft caulking in back of it.

C. Heat Shrinking Hail / Soft Dents in Sheet Metal

1. Steps 1 through 4

Step 1 Perform the “Preparation for Use” instructions.

Step 2 Set the power control knob to midway between the “Low” and “Max” settings.

Step 3 Step on the foot switch to turn the power ON.

Step 4 Holding the Concentrator® ½ to 1 inch above a dent, move it in a small circular motion and gradually bring it closer to the dent, but keeping it around the outside of the crown of the dent. As soon as the dent shrinks, back the Concentrator® away quickly and cool the treated dent with a damp rag. If the dent sucks in you are heating the crown or not far enough around the outside of the crown. Repeat the procedure until removed completely.

Tip: Once a puff of smoke releases from the dent immediately remove the Concentrator from the area. This is the point at which the paint will start to bubble. Also be careful on white and light colored finishes, these lighter paints tend to yellow sooner than darker colors.

Trouble Shooting: If the dent doesn’t seem to want to shrink, this may be because there is a crease in the metal or the metal has been stretched to far.

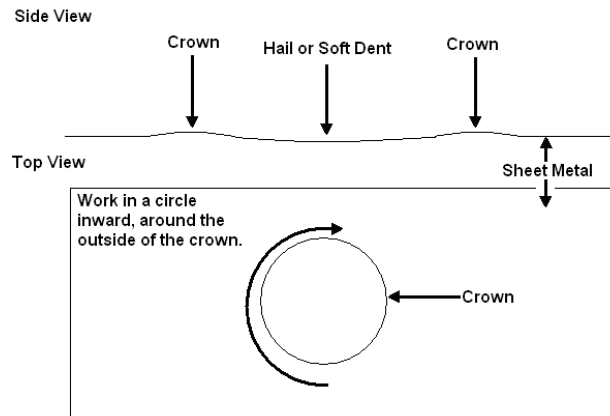

VIII. Using the Rosebud®

Function: The Rosebud (15) is used for frame rail straightening, aluminum annealing, de-bonding heavy gauged steal, etc.

A. Frame Rail Straightening

Step 1 Perform the “Preparation for Use” instructions.

Step 2 Set the control knob to Max/Glass Blaster® setting.

Step 3 Be sure that the Rosebud Heat shield is sitting in place.

Step 4 Connect the air regulator gauge to a clean dry compressed air source. Adjust the air regulator to 15-20 psi. Keep the air flow through the entire use

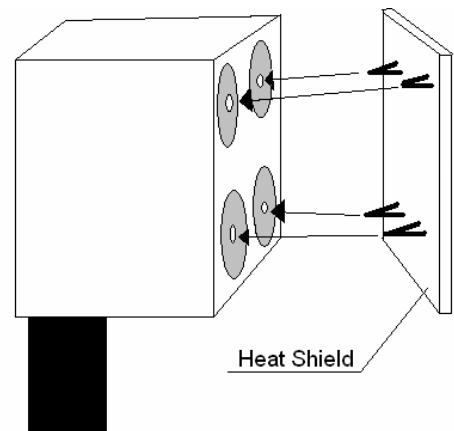

of the Rosebud and for two minutes after use. Failure to keep proper air flow may result in unwarrantable damage.

Step 5 Apply the Rosebud to structural metal component. Be sure to follow car manufacture recommended maximum temperature limits using a temperature indicator. Failure to do so may result in altering metal properties and reducing or eliminating function of the part.

B. Aluminum Annealing

Step 1 Perform the “Preparation for Use” instructions.

Step 2 Set the control knob to Max/Glass Blaster® setting.

Step 3 Be sure that the Rosebud Heat shield is sitting in place. If heat shield is damaged badly and unable to perform its function call Induction Innovations, Inc. at 877-688-9633 for a replacement shield.

Step 4 Connect the air regulator gauge to a clean and dry compressed air source. Adjust the air regulator to 15-20 psi. Keep the air source running through the entire use of the Rosebud and for two minutes after use. Failure to keep proper air flow may result in unwarrantable damage.

Step 5 Apply the Rosebud to Aluminum panel for stress relieving. When working with painted surfaces, applying a cloth over the heat shield will help prevent from scratching the surface.



Heating some aluminum alloys above 350 degrees F, can degrade the metallurgical properties. Consult the metal manufacturer for safe temperature limits and guidelines.

IX. Trouble Shooting

1. The Inductor® inverter is designed to stop running if overheated. If the unit stops suddenly: check for proper GFI operation and insure unit is still plugged into a functioning AC power outlet. Also be sure if using an extension cord that there are no cuts in the cord. Allow the unit to cool off for at least 30 minutes and then restart. If problems persist call Induction Innovations, Inc. at **877-688-9633**.
2. . If there is a lack of power output, this may be from using an improper extension cord or a damaged attachment. The proper gauge and length cord is 25 ft., 14-AWG or 50-ft, 12-AWG. Do not use more than one extension cord at once.
3. For other problems contact Induction Innovations, Inc. at 877-688-9633

X. Disassembly and Storage

Step 1 When you are finished working, turn the power OFF by releasing the foot switch and make sure that the beeping stops. If the Inductor® will not turn OFF by releasing the pressure on the foot switch, set the tool down in a place where it will not heat anything metallic, and disconnect the plug from the service outlet or extension cord. Call Induction Innovations, Inc. at **877-688-9633** for instructions on how to return the unit for repair.

Step 2 Disconnect the plug (11) from the service outlet or extension cord.

Step 3 (If applicable) disconnect the tool from the HF female output connector (6). Separate the halves of the connector by squeezing and holding open the plastic latches of the connector on the tool electrical cord to disengage them from the detents on the inverter tool power cord connector, and then pull the two connector halves apart.

XI. Cleaning Instructions

A. Proper Cleaning Care

Step 1 Use a dry, clean, non-abrasive cloth or paper towels to remove grease, oil, and other dirt from the tools, electrical cords, connectors and foot switch before returning them to the storage case.

Step 2 For grease, oil and dirt that is more difficult to remove use generally available nonvolatile automotive interior cleaning products.

Allow all components to dry completely before using the Inductor®.

B. Improper Cleaning Care

- Do NOT immerse any components of the unit in water or a cleaning solution.
- Do NOT spray the unit with a stream of water from a hose, or wash any parts under a stream of water from a faucet, hydrant or shower.
- Do NOT clean any components with volatile organic compounds such as gasoline, benzene, kerosene, methyl ethyl ketone (MEK), fuel oil, brake part cleaners, paint remover and thinners, varnish removers, plastic adhesive solvents, etc. These substances are fire hazards and will harden or dissolve the polymer materials used in the Inductor® components.
- Do NOT use heat guns, space heaters, torches, microwave or gas ovens, etc. to dry the components of the Inductor® after cleaning.

XII. WARRANTIES AND/OR REPAIRS

A. LIMITED WARRANTY

1. Induction Innovations Inc. warrants the Inductor® Max and Inductor® Glass Blaster® and any parts thereof, to be free from defects in materials and workmanship for one year from the date of first purchase, excluding all attachments or hand held tools which are warranted for six months, when operated in accordance with the *Operating and Safety Instructions Manual*. Induction Innovations Inc. warrants the Inductor® Pro Max and any parts thereof, to be free from defects in materials and workmanship for two years from the date of first purchase, excluding all attachments or hand held tools which are warranted for six months, when operated in accordance with the *Operating and Safety Instructions Manual*. This warranty is extended to the original purchaser, when proof of purchase is provided. Induction Innovations Inc. will cover ground transportation costs when returning a unit repaired under warranty. This warranty covers only the cost of parts and labor to restore the product to proper operating condition. Transportation and incidental costs associated with warranty repairs are not reimbursable under this warranty. Warranty service is available only through Induction Innovations Inc. This warranty does not cover defects resulting from misuse, abuse, negligence, accidents, normal wear, alteration, modification, tampering, or repair by anyone other than the manufacture. This express warranty is given in lieu of any other warranty either expressed or implied, including warranties of merchantability and fitness for a particular use. Induction innovations Inc. assumes no responsibility for indirect, incidental or consequential damages. Some states do not allow the exclusion or limitations of incidental or consequential damages or limitations or exclusions may not apply to you. This Limited Warranty gives you specific legal rights and you may also have other rights which vary from state to state. Warranty is not valid unless the warranty card is returned within 30 days of the date of purchase. No unit will be warranted without proof of purchase. Shipping will be at the consumer's own expense. Return shipping will be at the factory's expense for units repaired under warranty. Return shipping will be via ground, unless the consumer wishes to pay for faster service. Induction Innovations Incorporated is not responsible for lost, stolen, or damaged unit(s) due to shipping. Warranty is non-transferable. When returning an Inductor®, all attachments and accessories must be returned with the unit to qualify it for warranty repair. Call **877-688-9633** for return authorization prior to shipment.

Warranty & Repair Service

Induction Innovations, Inc.
1175 Jansen Farm Court
Elgin, IL 60123

XIII. Definitions

- **Anneal:** [uh-nee] ¹to heat metals to remove or prevent internal stress.
- **Ampere:** [am-peer, am-peer] ¹the base SI unit of electrical current, equivalent to one coulomb per second. *Abbreviation:* A, amp.
- **AWG:** ¹abbreviation for American Wire Gauge.
- **Capacitance:** [kuh-pas-i-tuh ns] ¹the property of being able to collect a charge of electricity. *Symbol:* C
- **Celsius:** [selsiəs] or centigrade, ¹ Of or relating to a temperature scale that registers the freezing point of water as 0° and the boiling point as 100° under normal atmospheric pressure.
- **Circuit:** [sur-kit] ¹ Also called electric circuit. the complete path of an electric current, including the generating apparatus, intervening resistors, or capacitors.
- **Concentrator®:** [kon-suh n-treyt] ¹a registered product name inductor used for removal of hail dents, frozen nuts, and other frozen or rusted hardware from cars.
- **Conductivity:** [kon-duhk-tiv-i-tee] ¹ Also called specific conductance. *Electricity.* a measure of the ability of a given substance to conduct electric current, equal to the reciprocal of the resistance of the substance. *Symbol:* σ
- **Current:** [kur-uh nt,] ¹the time rate of flow of electric charge, in the direction that a positive moving charge would take and having magnitude equal to the quantity of charge per unit time: measured in amperes.
- **Degree:** [di-gree] ¹a unit of measure, as of temperature or pressure.
- **Eddy Current:** [ed-ee kur-uh nt] ¹an electric current in a conducting material that results from induction by a moving or varying magnetic field.
- **Electromagnetic Interference:** [i-lek-troh-mag-net-ik in-ter-feer-uh ns] ¹Any electromagnetic disturbance that interrupts, obstructs, or otherwise degrades or limits the effective performance of electronics/electrical equipment. *abbreviation E.M.I.*
- **Fahrenheit:** [far-uh n-hahyt] ¹Of or relating to a temperature scale that registers the freezing point of water as 32° and the boiling point as 212° at one atmosphere of pressure
- **Farad:** [far-uh d] ¹the SI unit of capacitance, formally defined to be the capacitance of a capacitor between the plates of which there appears a potential difference of one volt when it is charged by a quantity of electricity equal to one coulomb. *Symbol:* F
- **Fast Off®:** [fast awf] ¹a registered product name inductor used for removal of body side moldings, vinyl graphics, and other adhesive bonded parts to automobiles.
- **Ferrite:** [fer-ahyt] ¹ *chemistry* a compound, as NaFeO₂, formed when ferric oxide is combined with a more basic metallic oxide. ² *Metallurgy* the pure iron constituent of ferrous metals, as distinguished from the iron carbides
- **Ferrous:** [fer-uhs] ¹of or containing iron.
- **Flux:** [fluhks] ¹The lines of force of an electric or magnetic field.
- **Frequency:**[free-kwuh n-see] ¹the number of cycles or completed alternations per unit time of a wave or oscillation. *Symbol:* F; *Abbreviation:* freq.
- **G.F.I.:** *see Ground Fault Interrupter.*
- **Glass Blaster®:** [glahs, glas] ¹a registered product name inductor used for removal of automotive glass and body panels. Can be an attachment or a single attachment hardwired unit.
- **Ground Fault Interrupter:** [ground fawlt in-tuh-ruhp-ter] ¹a circuit breaker that senses currents caused by ground faults and rapidly shuts off power before damage can happen to generating equipment.
- **Henry:** [hen-ree] ¹ the SI unit of inductance, formally defined to be the inductance of a closed circuit in which an electromotive force of one volt is produced when the electric current in the circuit varies uniformly at a rate of one ampere per second. *Abbreviation:* H
- **Hertz:** [hurts] ¹ the SI unit of frequency, equal to one cycle per second. *Abbreviation:* Hz
- **Hysteresis:** [his-tuh-ree-sis] ¹the delay in response exhibited by a body in reacting to changes in the forces, esp. magnetic forces, affecting it.
- **HF:** (High Frequency [hī free-kwuh n-see]) ¹the range of frequencies in the radio spectrum between 3 and 30 megahertz.\
- **Inductance:** [in-duhk-tuh ns] ¹ that property of a circuit by which a change in current induces, by electromagnetic induction, an electromotive force. *Symbol:* L

- **Induction:** [in-duhk-shuh n] ¹the process by which a body having electric or magnetic properties produces magnetism, an electric charge, or an electromotive force in a neighboring body without contact.
- **Inductor:** [in-duhk-tor] ¹a coil used to introduce inductance into a ferrous work piece.
²(Inductor®) A registered brand name of the only patented induction heating system for the automotive aftermarket.
- **Inverter:** [in-vur-ter] ¹a device that converts direct current into alternating current.
- **Kilowatt:**[kil-uh-wot] ¹unit of power, equal to 1000 watts. *Abbreviation:* kW kw
- **Ohm:** [ohm] ¹ the SI unit of electrical resistance, defined to be the electrical resistance between two points of a conductor when a constant potential difference applied between these points produces in this conductor a current of one ampere. The resistance in ohms is numerically equal to the magnitude of the potential difference. *Symbol:* Ω
- **Resistance:**[ri-zis-tuh ns] ¹a property of a conductor by virtue of which the passage of current is opposed, causing electric energy to be transformed into heat.
- **Rosebud™:**[roh-z-buhd] ¹a registered product name inductor used for annealing, warming of frame rail for straightening, etc.
- **Temper:**[tem-per] ¹ the degree of hardness and strength imparted to a metal, as by quenching, heat treatment, or cold working. ² the operation of tempering.
- **Volt:** [vohlt] ¹the SI unit of potential difference and electromotive force, formally defined to be the difference of electric potential between two points of a conductor carrying a constant current of one ampere, when the power dissipated between these points is equal to one watt. *Abbreviation:* V
- **Voltage:** [vohl-tij] ¹electromotive force or potential difference expressed in volts.
- **Watt:** [wot] ¹the SI unit of power, equivalent to one joule per second and equal to the power in a circuit in which a current of one ampere flows across a potential difference of one volt.
Abbreviation: W, w.

XIV. Additional Training

A. Additional Training is available online through I-CAR

1. Induction Heaters (INH01)



My Inductor® Dealer:

Company: _____

Contact: _____

Address: _____

City _____ State ___ Zip _____

Phone #: _____

Alt. Phone #: _____

Fax #: _____

Email: _____

Website: _____

My Inductor:

Model:

Pro Max Max Glass Blaster

Serial #: _____

Notes: