

G520

OWNER'S MANUAL



INSTRUCTIONS

This manual contains important information concerning the installation and operation of the gun washers listed above. Read manual thoroughly and keep for future reference

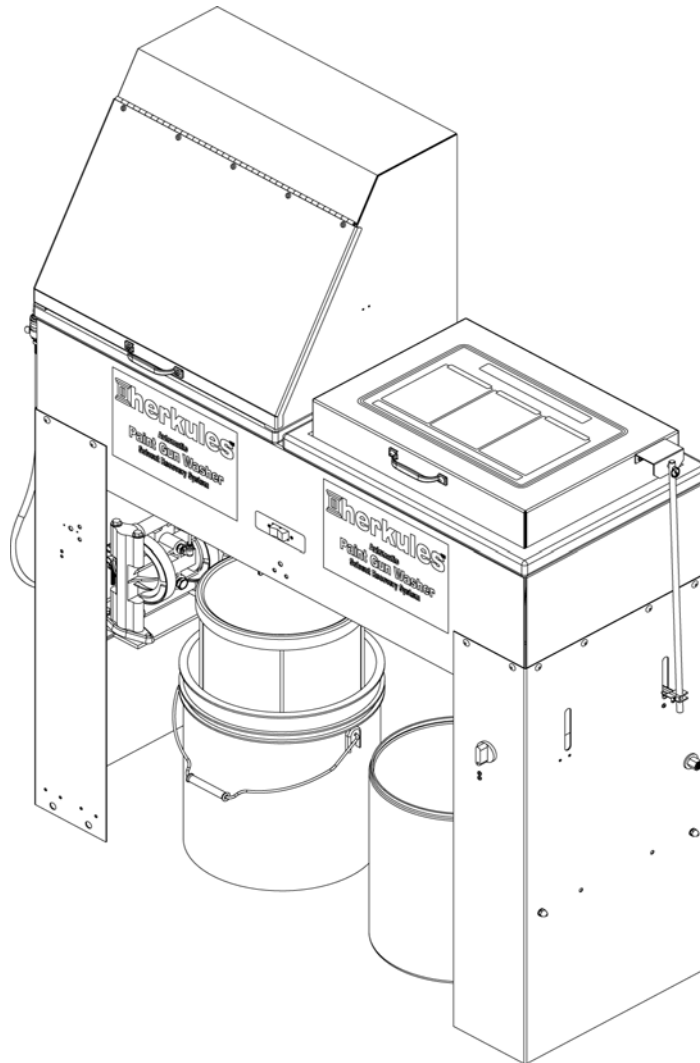

Herkules Equipment Corporation
248-960-7100

2760 Ridgeway Court
800-444-4351

Walled Lake, MI 48390-1662 USA
Fax 248 960-7109

Patents USA 7070167 4793369, 4960142, 5174317, 5193561, 5485860 Canada 1299468 & Patents Pending
website: www.herkules.us Made in the USA e-mail: info@herkules.us

Table of Contents

Warnings	3-4
Model Information	5
Installation	5
Operation	6-9
Preventive Maintenance	9
Troubleshooting	10
Drawings with part lists:	11-14

Warning Symbol



This symbol alerts you to the possibility of serious injury or death if you do not follow the instructions.

Caution Symbol



This symbol alerts you to the possibility of damage to or destruction of equipment if you do not follow the instructions.

Serial Number _____

Model Number _____

Purchase Date _____

Distributor _____

 herkules™ PATENT NUMBERS

This product has patent protection under one or more of the following patent numbers:

7070167, 5485860, 5193561, 5174317
4960142, 4793369, 1299468
and Patents Pending

website: www.herkules.us 1002742



WARNING



EQUIPMENT MISUSE HAZARD

Equipment misuse can cause the equipment to rupture, malfunction, or start unexpectedly and result in serious injury.

- This equipment is for professional use only.
- Read all instruction manuals, tags, and labels before operating the equipment.
- Use the equipment only for its intended use.
- Do not alter or modify this equipment.
- Do not exceed the maximum working pressure of the lowest rated system component.
- Do not operate the gun washer at a pressure above the maximum working pressure rating of the gun(s) being cleaned.
- Route the hoses away from traffic areas, sharp edges, moving parts, and hot surfaces.
- Do not use the hoses to pull the equipment.
- Do not move pressurized equipment.
- Use fluids or solvents that are compatible with the equipment wetted parts. Read the fluid and solvent manufacturer's warnings.
- Comply with all applicable local, state, and national fire, electrical, and other safety regulation.



PRESSURIZED EQUIPMENT HAZARD

Spray from hose leaks, ruptured components, or from operating the gun washer with an open lid can splash fluid in the eyes or on the skin and cause serious injury.

- A safety device has been installed to shut off the pump when the gun washer lid is opened. Do not tamper with or alter this device.
- Open the gun washer lid slowly.
- Do not stop or deflect fluid leaks with your hand, body, glove, or rag.
- Tighten all fluid connections before operating the equipment.
- Replace worn, damaged, or loose parts immediately.



WARNING



FIRE AND EXPLOSION HAZARD



Improper grounding, poor air ventilation, open flames, or sparks can cause a hazardous condition and result in fire or explosion and serious injury.

- Ground the equipment. See Installation for grounding procedure.
- Provide fresh air ventilation to avoid the build up of flammable fumes from the cleaning solution.
- Extinguish all open flames or pilot lights in the gun washer area.
- Disconnect all electrical equipment in the gun washer area.
- Keep the gun washer area free of debris, including cleaning solutions, rags, and gasoline.
- Do not turn on any light switch in the gun washer area while operating or if fumes are present.
- Do not smoke in the gun washer area.
- Do not operate a gasoline engine in the gun washer area.
- Follow the gun manufacturer's solvent and other cleaning recommendations.
- Use solvent with the highest possible flash point.
- If there is any static sparking while using the equipment, **stop operation immediately**. Identify and correct the problem.
- Drain the cleaning solution into a proper storage container when gun washer(s) is not in use.



TOXIC FLUID HAZARD

Hazardous fluids or toxic fumes can cause serious injury or death if splashed in eyes or on the skin, swallowed, or inhaled.

- Know the specific hazards of the fluid you are using. Read the fluid manufacturer's warnings.
- Store hazardous fluid in an approved container. Dispose of hazardous fluid according to all local, state and national guidelines.
- Wear the appropriate protective clothing, gloves, eyewear and respirator.
- Pipe and dispose of the exhaust air safely. If diaphragm fails, the fluid may be exhausted along with the air.

Model Information

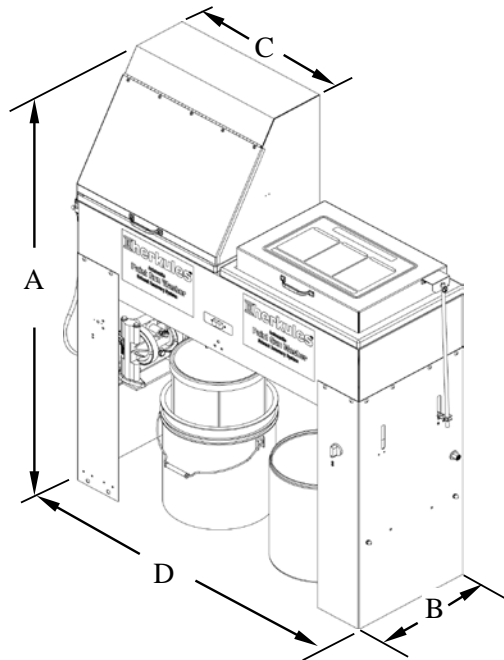

NOTE: Dimensions listed are overall measurements.

Model	Description	Weight lbs/(kg)	Dimensions in./(mm)			
			A	B	C	D
G520	Two independently operating washers. The left side is for manually cleaning water borne paints and the right side is for timed automatic cleaning of either waterborne or solvent based paints	141 (64)	51.38 (1305)	15.38 (391)	20.25 (514)	41.38 (1051)

Installation

Installing the Gun Washer

- 1) Place gun washer on a level surface in a properly ventilated paint mixing room or paint booth.

Grounding the Gun Washer

- 1) Connect the ground wire on the gun washer's pump to a true earth ground.
- 2) Ground all equipment used or located in the gun washer area.

Connecting the Air Line

- 1) Install a 1/4 in. npt male coupler, that is compatible with the quick disconnect of your air supply line, into the air supply port of the filter/regulator located on the right leg.
- 2) Connect air line with at least 75 psi to the coupler. Filter/regulator is preset. Do not adjust.

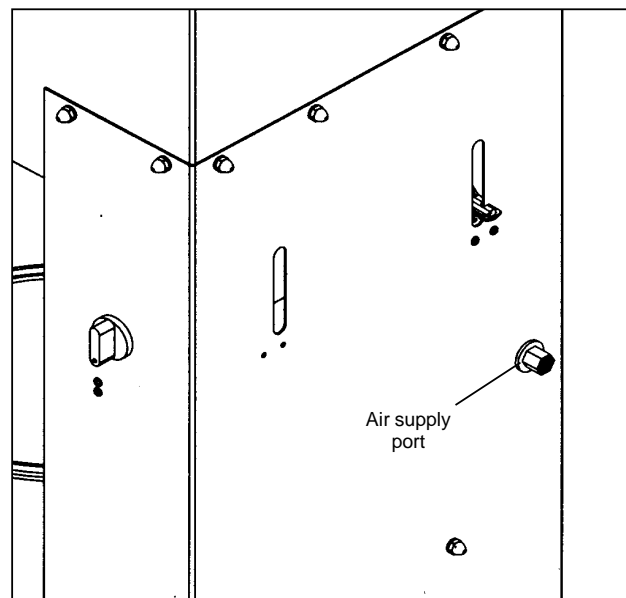

Operation

Manual cleaning of water borne paints (left side)

Connecting the water to the washer

- 1) Insert the filter mount frame into the bucket.
- 2) Fill with distilled water until the water level reaches the bottom of the filter support cross arms.
- 3) Connect the large filter bag to the filter mount frame so that the bottom of the filter is resting on the filter support.
- 4) Insert the small filter bag into the large bag and connect to the filter mount frame.
- 5) Place the bucket under the Gun Washer and insert the pick up tube between the bucket wall and the filter.
- 6) Close ball valve.

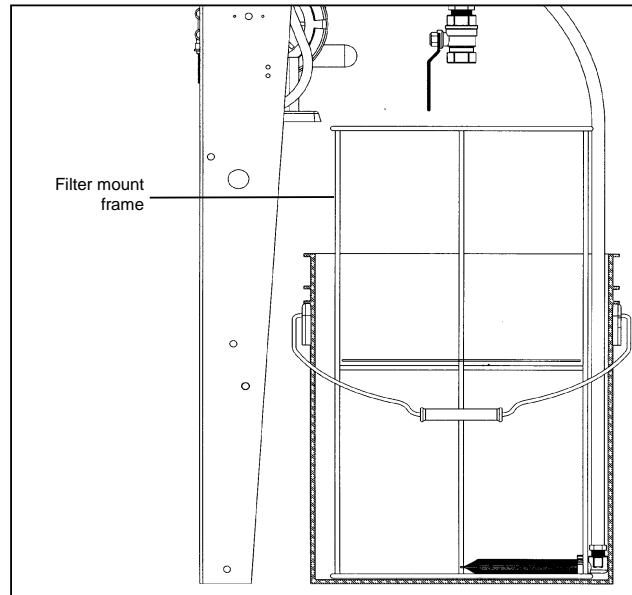

Preparing the Equipment to be washed

- 1) Remove paint cup or paint line and the air line from the paint gun.
- 2) Drain excess paint from cup and gun into a separate container.
- 3) Remove all gauges and regulators from painting equipment.
- 4) Remove the air cap/fluid tip from the paint gun (for manual cleaning only).
- 5) Connect the air channel line to the spray gun using the supplied quick disconnects or replace the supplied quick disconnects with ones compatible with the shops equipment.

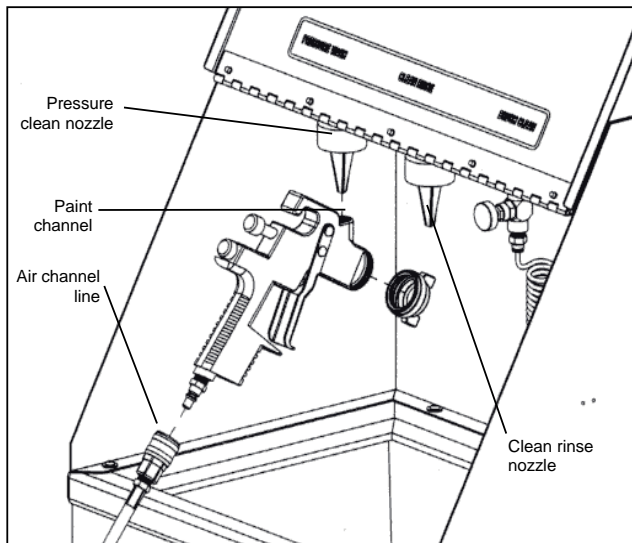

⚠ CAUTION

All pressure gauges must be removed before placing the equipment in the gun washer to avoid damaging the gauges (for Automatic Cleaning only).

Note: Position the spray gun so that the flow of water exiting the paint gun is contained within the Gun Washer tub.

Operational Note:

- 1) The left (waterborne) side of the Gunwasher is set up to deliver water on demand for cleaning. This means that the left side pump **MUST** have a full draw bucket available when plugging the Gunwasher into plant air. If a bucket is not available, the pump will continue to cycle until a draw bucket is placed to supply water pressure to the Pressure Wash nozzle and the Manual Brush nozzle. Once water pressure is delivered to these ports, the pump will stop cycling. The pump may also cycle periodically to maintain water pressure to the Pressure Wash nozzle and the Manual Brush nozzle.

Cleaning Equipment

- 1) To activate manual clean brush, turn handle on valve until water starts to flow. Flow can be adjusted using the handle on the manual brush valve.
- 2) Position the spray gun so the pressure clean nozzle is inserted into the paint channel of the spray gun. Lift up with the gun while squeezing the trigger to activate the push valve to send a pressurized flow of water through the gun's paint channel.

Operation

Clean rinse

- 1) Fill an additional bucket (not supplied) with distilled water.
- 2) Insert the clean rinse inlet tube located on the left side of the Gun Washer in the bucket.
- 3) Set the rinse / agitator switch on the front of the Gun Washer to rinse.
- 4) Position the spray gun so the clean rinse nozzle is inserted into the paint channel of the spray gun.
- 5) Squeeze the trigger of the spray gun while lifting up with the gun to send a pressurized flow of clean water through the gun's paint channel.
- 6) Return the rinse / agitator switch to the neutral position when finished.
- 7) Use the air gun to dry off any wet components.

Note: Reuse the cleaning solution / water mixture until it becomes tacky to the touch. Dispose of all waste materials according to local, state, and federal regulations.

- 7) Empty the paint waste out of the inner filter. Place inner filter back on the filter holder for up to 10 uses.
Note: place solid waste onto a piece of cardboard to finish drying. This will speed the process as the cardboard will absorb the moisture from the paint debris.
- 8) Close the ball valve. Replace filter bags (P/N 1003348 & P/N 1003351) as needed.
- 9) Dispose of all waste materials according to all local, state, and federal regulations.
- 10) Wipe inner tank after each use.

Filtering Dirty water (optional)

- 1) Remove the cleaning platform from inside of the left tank.
- 2) Pour the dirty paint mixture to be recycled into the tank. Do **not** exceed the 5 gallon capacity of the tank.
- 3) Add flocculant / coagulant to the dirty paint mixture. (Herkules CoAgent P/N CA01 recommended).

Note: Contact local distributor to purchase flocculant/coagulant. Amount of flocculant/coagulant required will vary depending on the brand of flocculant being used.

- 4) If using Herkules CoAgent P/N CA01, add 1 tablespoon per 5 gallons of dirty paint mixture.
- 5) Set the switch on the front of the Gunwasher to Agitator. Stir mixture for 30 seconds during agitation. Allow the dirty paint mixture / flocculant mix to agitate for 30 to 120 seconds (dependent upon quality of flocculant). Let the mixture sit for 30 seconds. Return the agitator switch to the Off position.

Note: Repeat process if adequate separation does not occur (dependent upon quality of flocculant).

- 6) Open the ball valve to allow the mixture to drain through the filter bags. The filter bags capture the paint debris, and the bucket captures the filtered cleaning solution / water mixture that can be reused for cleaning.

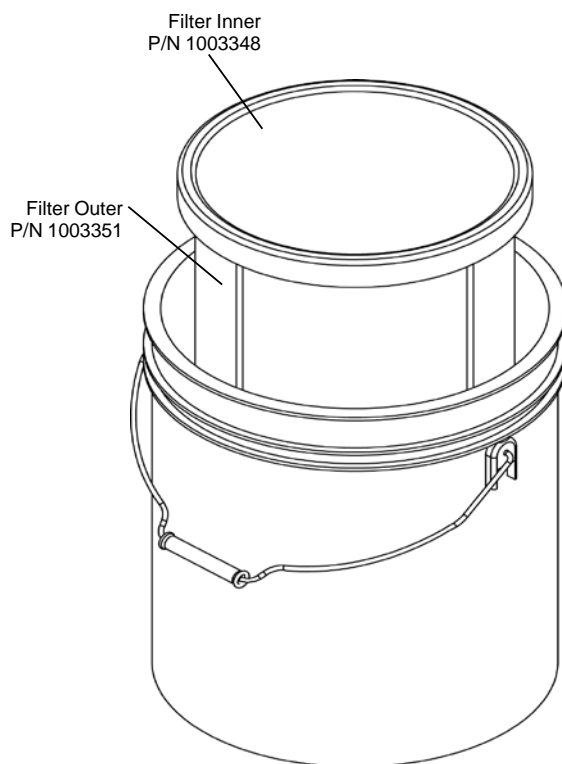

Operation

Automatic cleaning of all paints (right side)

Note: Once right side has been used for solvent based paints, it cannot be used for waterborne paints. Once right side has been used for waterborne paints it cannot be used for solvent based paints.

Connecting the Solvent to the Washer

- 1) Insert the drain pipe and siphon tube into a fresh 5 gallon solvent can and secure the plug in the opening.
- 2) The can must contain at least 2.5 gallons of solvent to pump properly. Use a high quality solvent.

Preparing the Equipment to be washed

- 1) Remove paint cup or paint line and the air line from the paint gun.
- 2) Drain excess paint from cup and gun.
- 3) Remove all gauges and regulators from painting equipment.
- 4) Lock the gun trigger in the open position by placing the trigger lock around the gun handle and trigger.

Placing Equipment in the Gun Washer

To clean guns not mentioned here, use the long or short stem supports as needed (see pg.14). For questions or adapter kits contact your paint gun washer distributor.

Siphon Feed Guns

Place the gun siphon tube on the short stem support.

Gravity Feed Guns (HVLV)

Place the long stem support over the short stem support. Place paint inlet of gun on long stem support. Place the air cap assembly over the air inlet of the gun to prevent solvent from entering the passage.

Pressure Feed Guns

Place long stem support over the short stem support. Place paint inlet of gun on long stem support.

Pots and Cups

Place a pot or a cup on the cup holder.

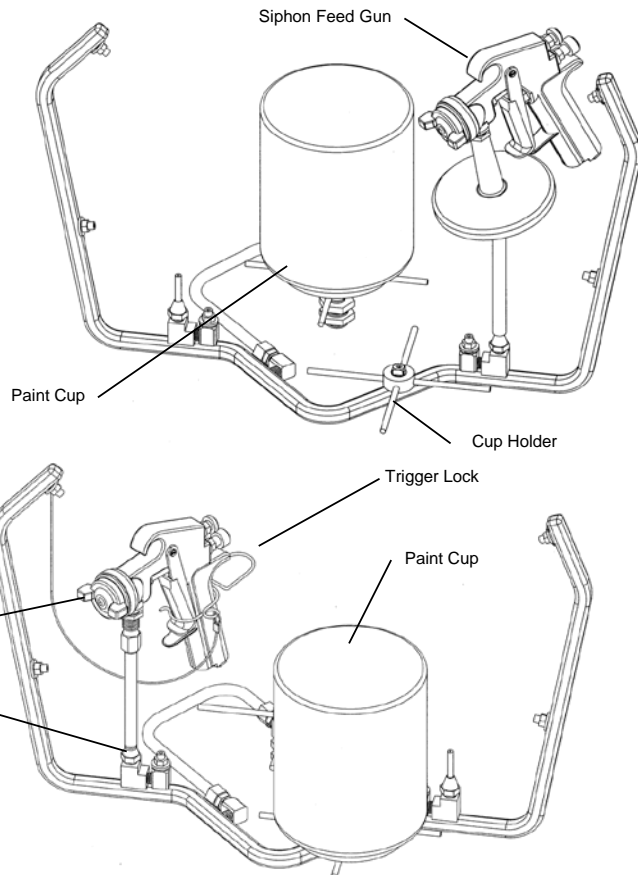
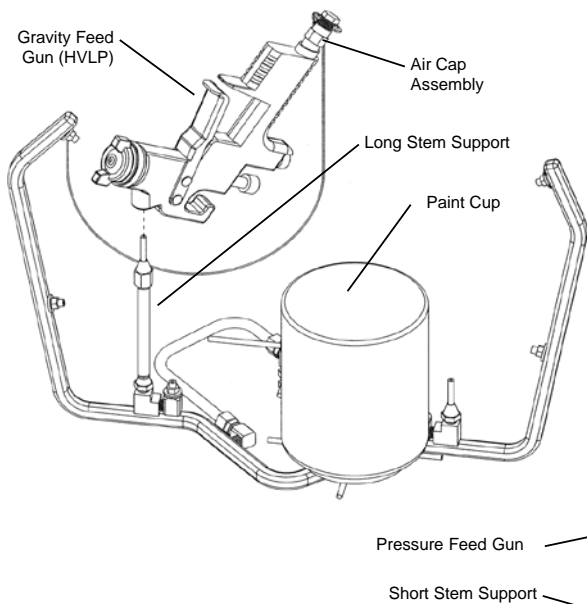

Note:
Only one gun & one cup shown for clarity.

Operation

Operating the Gun Washer

- 1) Make sure wire trigger locks and other accessories are inside the gun washer tank.
- 2) Place equipment in the tank according to the diagrams shown on page 8.
- 3) Close the gun washer lid.
- 4) Turn the timer knob clockwise 90 degrees to start the gun washer. The gun washer will run for 90 seconds. Turning the timer knob less than 90 degrees will reduce the timing cycle. Paint equipment will clean in 60 to 90 seconds.
- 5) If the lid is opened prior to the end of the timing cycle, the safety air cutoff switch will stop the gun washer. The gun washer will start again when the lid is closed if time remains on the timer.
Note: Open the lid slowly to minimize vapor escape.
- 6) Remove the equipment from the gun washer and wipe off any remaining solvent.

Preventive Maintenance

- 1) Drain excess paint from cup or pot before placing in gun washer.
- 2) Drain paint sludge from 5 gallon solvent can weekly. Do this after a weekend so the sludge has settled.
 - Access the solvent can by removing the drain hose from the can, then remove the nylon plug from the can.
 - Pour the solvent into a second container and drain the sludge into a disposal container. Refill can from the second container and add solvent to reach the 2.5 gallon minimum, or the can half-full.
 - Clean siphon tube with cloth and brush to remove residue.
- 3) Remove the filter bowl and check the filter inside the regulator for excess buildup approx. every 6 months.
- 4) Change solvent completely when objects being cleaned become tacky to the touch.
- 5) Clean inside of tub and internal manifold.

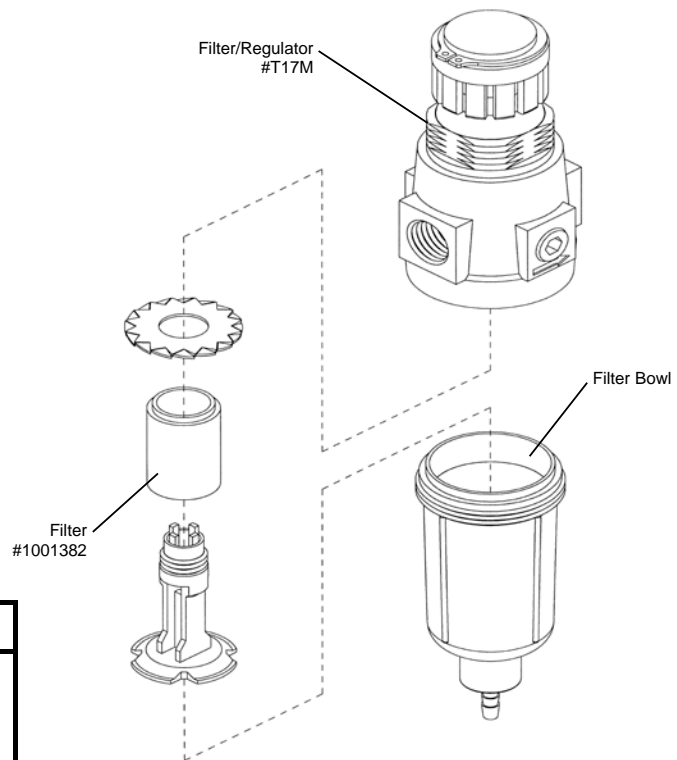

CAUTION

Do not change the setting of the filter/regulator. This could damage the filter/regulator or pump.

Troubleshooting

Problem	Possible Solution
Gun washer will not turn on. (automatic)	<ol style="list-style-type: none"> 1 Make sure the air line is properly connected with at least 75 psi. 2 Make sure lid is fully closed. Make sure the lid rod actuator is making full contact with the limit valve on the right rear leg. 3 Check all air connections to ensure that there are no leaks. 4 Make sure timer cam is engaging the limit valve on the right front leg. 5 Make sure timer is on and functioning correctly.
Pump turns on but wash water does not flow. (manual)	<ol style="list-style-type: none"> 1 Make sure wash bucket is not empty. 2 Make sure the filter at the end of the pick up tube is completely submerged in water. 3 Check all fluid connections to ensure that there are no leaks.
Gun washer turns on but pumps slowly or not at all.	<ol style="list-style-type: none"> 1 Make sure intake filter is not clogged (Clean or replace). 2 Make sure the air line is properly connected with at least 75 psi. Air pressure is regulated at 75 psi. 3 Check all air connections to ensure that there are no leaks. 4 Make sure there is 2.5 gallons of clean solution in the gun washer. The cleaning solution should be an inch above the intake filter. 5 Make sure lid is fully closed. Make sure the lid rod actuator is making full contact with the limit valve on the right rear leg. 6 Make sure manifold nozzles and stem supports are not clogged.
Gun washer will not shut off	<ol style="list-style-type: none"> 1 Make sure timer cam is moving. If it's not, slightly loosen the nuts holding the limit valve on the right front leg of the stand. Reposition valve and tighten nuts. 2 Make sure limit valves located on the right and left legs of the stand are not stuck in closed position. 3 Make sure line is hooked in correctly to the limit valve.
No flow through the manual brush.	<ol style="list-style-type: none"> 1 Make sure wash bucket is not empty. 2 Make sure the filter at the end of the pick up tube is completely submerged in water. 3 Check all fluid connections to ensure that there are no leaks. 4 Make sure valve handle is not closed all the way.

G520 Parts Layout

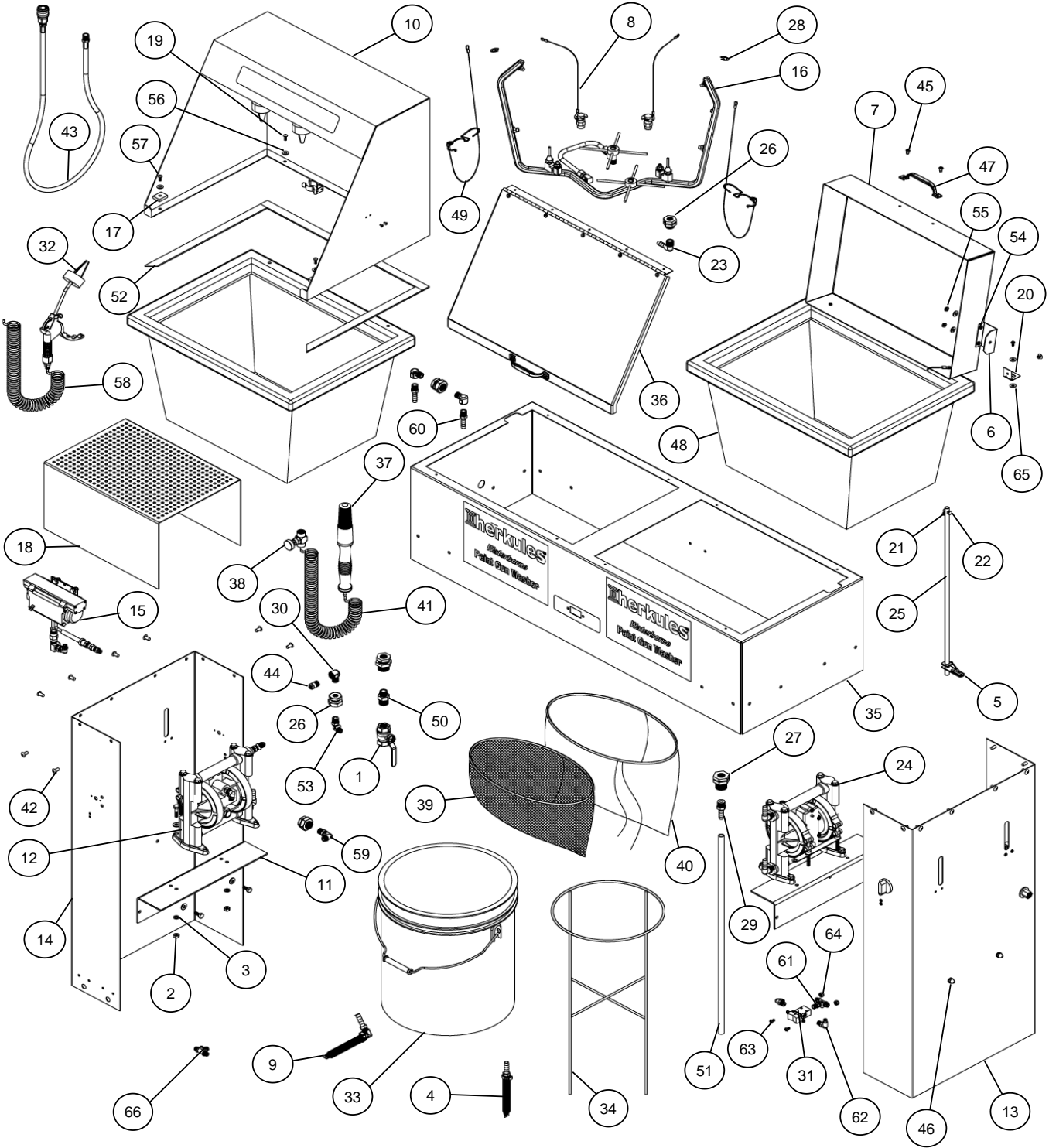

G520 Parts Layout

	Part #	Description	Quantity	
1	6	Ball Valve	1	EA
2	84	Nut Hex 1/4-20	4	EA
3	85	Lock Washer 1/4	8	EA
4	11243	Filter Assembly	1	EA
5	11957	Actuator	1	EA
6	12131	Actuator Bracket for G100	1	EA
7	12132	Lid for G100	1	EA
8	12509	Air Cap Assembly	2	EA
9	13053	Filter Assembly	1	EA
10	13107	Shroud assembly	1	EA
11	11958	Pump Bracket	2	EA
12	13124	Pump Assembly	1	EA
13	13125	Right Leg Assembly	1	EA
14	1002970	Leg For Double Tank GWR Stand	1	EA
15	13430	Rinse Pump Assembly	1	EA
16	13129	Manifold Assembly	1	EA
17	13899	Deflector Block	2	EA
18	13901	Cleaning Platform	1	EA
19	1003889	Screw HWH 10-24 x 1/2 SS	2	EA
20	39C	Butt Hinge 1 X 2 X .035 SS w/holes	2	EA
21	1000252	Cotter Ring	1	EA
22	1000652	Clevis Pin	1	EA
23	1000967	Hose Barb 90 deg 3/8 x 1/4 NPT	1	EA
24	13123	Pump Assembly	1	EA
25	1002572	Actuator Rod	1	EA
26	1002643	Bulkhead 3/4 - Brass	4	EA
27	1002644	Bulkhead 1 - Brass	2	EA
28	1002651	E-ring - Stainless	2	EA
29	1002654	Hose Barb 3/8 x 3/8 NPT	1	EA
30	1002779	Elbow 1/4 NPT - Brass	3	EA
31	1002912	Toggle Valve	1	EA
32	13800	Air Gun	1	EA
33	1002914	Bucket 5-Gallon	1	EA
34	1002967	Filter Mount Frame	1	EA
35	1002969	Frame	1	EA
36	1003272	Lid	1	EA
37	1000563	Brush	1	EA
38	1003172	Needle valve 1/4 NPT	1	EA
39	1003348	Filter - inner	1	EA
40	1003351	Filter - outer	1	EA
41	1003459	Tube Coiled 1/4	1	EA
42	1003597	Rivet 1/4 X 1/2 Aluminum Blind	16	EA
43	14141	Whip Line Assembly	1	EA
44	002-134	Agitator Nozzle	1	EA
45	14C	Rivet 3/16 x 1/2 Aluminum	16	EA
46	008-244	Acorn Nut 1/4-20	4	EA
47	10A	Handle	2	EA
48	1-MINI-BLUE	Tub Plastic	2	EA
49	22BA	Trigger Lock	2	EA
50	62	Adaptor 1/2 NPT x 3/8 NPT	1	EA
51	64PE	Hose 1/2 - Black PE	23	IN.
52	69	Foam Seal	49	IN.
53	T25	Hose fitting 5/32 x 1/4 NPT	1	EA
54	005-131	Screw PHM Phillips 10-24 x 1/2 SS	2	EA
55	005-132	Nut Hex 10-24 SS	2	EA
56	1002656	Washer Flat #10 Nylon	6	EA

See pg. 13

G520 Parts Layout

	Part #	Description	Quantity	
57	002-175S	Screw BHSC 10-24 x 3/4 SS	2	EA
58	1002968	Tube Coiled 5/32 OD x 6 Nylon	1	EA
59	002-118	Fitting PTC 90 Deg Swivel 1/4 x 1/4 NPT	1	EA
60	57	Fitting Compression 1/2 T x 3/4 NPT Brass	2	EA
61	1000818	Tee Street PTC 5/32 x 1/8 NPT	1	EA
62	002-129	Fitting PTC 90 Deg Swivel 5/32 x 1/8 NPT	2	EA
63	1002546	Screw BHSC 10-24 x 1/2	2	EA
64	005-137	Nut Nylock 10-24 Z	2	EA
65	002-161	Washer Flat #10 USS Z	4	EA
66	1000852	Tee PTC 5/32	1	EA

G520 Manifold Layout

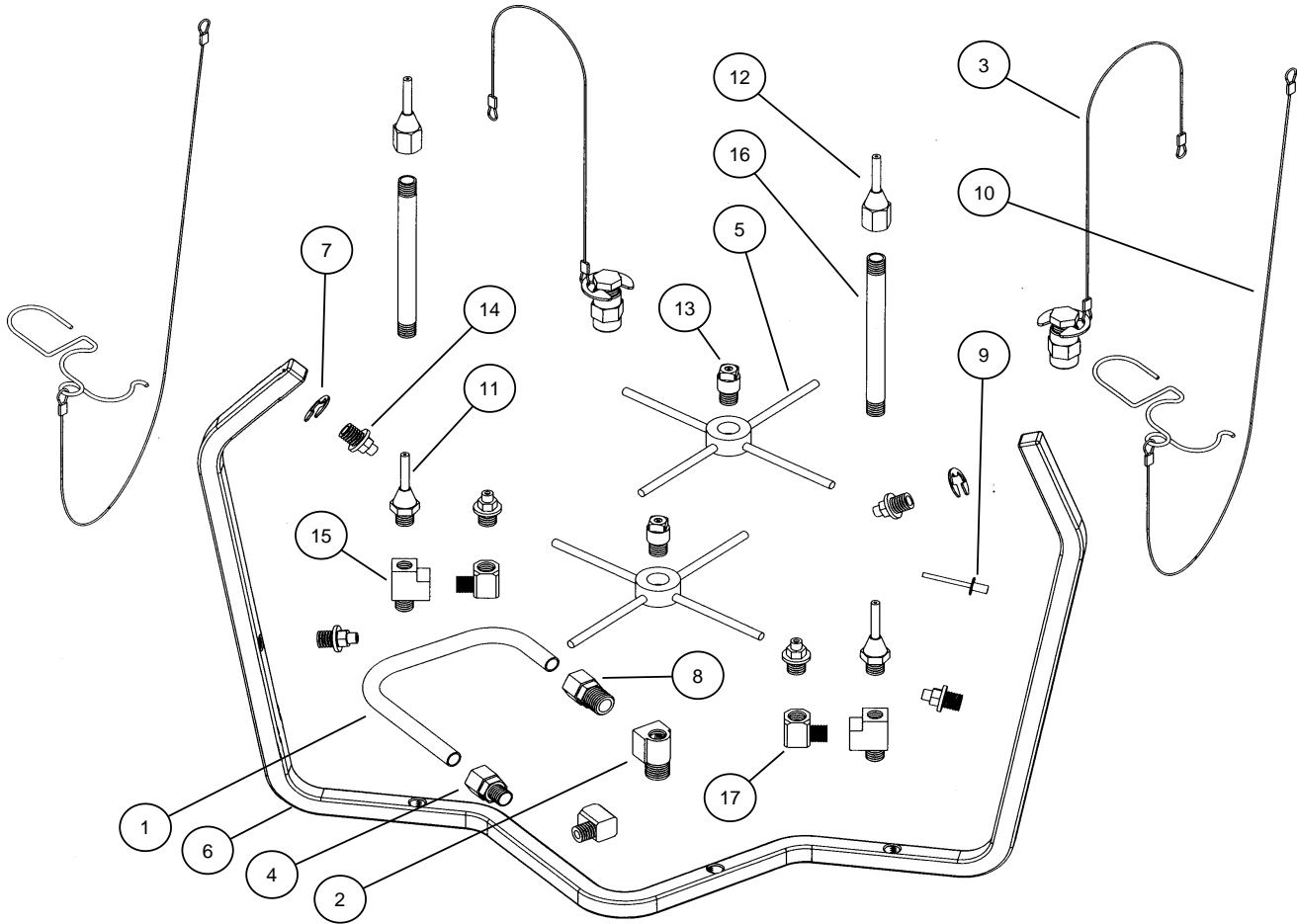

Part #	Description	Quantity
1	10283 Bent Manifold Tube - Stainless	1 EA.
2	10284 Tee 1/4 NPT - Brass	1 EA.
3	12509 Air Cap Assembly - Brass and Stainless	2 EA.
4	1000115 Compression Fitting 1/8 - Brass	1 EA.
5	1002422 Cup Holder - Stainless	2 EA.
6	1002529 Manifold - Stainless	1 EA.
7	1002651 E-ring - Stainless	2 EA.
8	002-143 Compression Fitting 1/4 - Brass	1 EA.
9	002-192 Rivet	1 EA.
10	22BA Trigger Lock Assembly	2 EA.
11	53A Stem Support Male	2 EA.
12	53B Stem Support Female	2 EA.
13	54 Full Jet Nozzle - Brass	2 EA.
14	54P1 Full Jet Nozzle - Kynar	6 EA.
15	C12D Tee 1/8 NPT - Brass	2 EA.
16	C9A Nipple 4-1/2" - Brass	2 EA.
17	M6 Elbow 1/8 NPT - Brass	3 EA.

Note: Parts are shown for reference purposes only and are not necessarily part of a Herkules assembly.