

COL-MET Spray Booths

Installation Directions

GENERAL:

This instruction manual is a guide for installing a variety of paint booths. The assembly drawings enclosed are specifically for the paint booth you have purchased. This drawing is an exploded isometric showing the relationship of each panel or part to the next one.

A packing list of all components is provided and should be used in addition to the drawing when uncrating your booth to correctly identify all components.

All DAMAGES MUST be reported within 24 hours of receipt and a freight claim filed with the carrier.

PRELIMINARY:

COL-MET booths are manufactured in accordance with NFPA 33, OSHA CFR 29.1910.107; however, local codes and regulations may apply to the installation and use of this product. It is recommended that all permits and approvals be obtained prior to installation and use of the spray booth.

1. Tools needed:
 - Pry Bar
 - Claw Hammer
 - Drift Pin
 - Assorted Wrenches (pneumatic tools are more efficient)
 - Drill with 3/8" bit
 - Screw Driver
 - 2" x 4" Studs (or other suitable support method) for Supporting walls and/or gables during installation.
 - 2 Ladders (8' – 10')
 - *Hint: A Drywall Lift can be rented inexpensively and will Save time.*
2. Uncrate and inventory all spray booth components to ensure all of the parts are accounted for. Each component is numbered on the exploded view. Stack all common panels together.
3. The floor surface of the booth must be non-combustible material of such character as to facilitate the safe cleaning and removal of residues. The floor surface of the booth must be flat and level to avoid problems with erection and alignment of panels.
4. Using a chalk line, mark the dimensional outline of the booth on the floor.
5. Follow the step-by-step instructions provided.

Planning Ahead

While planning the exact location of your new paint booth, keep the following specifications in mind, as they are **Your Responsibility:**

A.) Clearances between other work areas and combustible storage areas must be held as follows:

- 1.) 3 ft. minimum clearance at all sides and sealed entry ways (i.e., door ways).*
- 2.) 5 ft. minimum clearance at all non-sealed entry ways (i.e., the open face of the IB booth or a silhouette openings).*

B.) A minimum of a 10 ft. clearance must be held between the exhaust stack of the booth and the intake of another apparatus. NFPA 33 dictates a minimum discharge clearance of 5' from the nearest combustible material; however, stack height requirements vary with individual states and may be up to 1½ times the building's roof height from grade.

C.) A minimum of a 10 ft. clearance must be held between the intake of this booth and the exhaust of any other apparatus.

E.) Permits are not included. It is the responsibility of the end user to acquire all permits to install a paint booth.

F.) A fire suppression system is not included with the booth. Generally this is supplied and installed by a licensed local installer.

*G.) The fan, motor, & drive are included; however, the air solenoid valve & a Control Panel with main disconnect switch, motor starter(s) with fuse protection, fire protection interlock, light switches, and terminals for light hook up are **not** included but may be purchased optionally from Col-Met. (The electrician wiring the booth supplies wiring, conduit etc.)*

H.) Don't forget to verify the electrical current available. All fans on Col-Met paint booths with electrical motors larger than 1 horsepower will require three phase electricity as standard power unless the single phase option is ordered.

Please Read:

Under no circumstances shall this booth be considered a load bearing structure... DO NOT walk on, stand on or use the spray booth as a support structure before, during, or after installation.

Hints: *When assembling the booth, you should leave the bolts FINGER TIGHT ONLY until each section is assembled. All flanges should face outward. The nut end of the bolt should protrude outward (bolt heads inside the booth). Use a drift pin to align panel holes when two or more panels are difficult to align by hand. Floor anchors should be used at a minimum of every 12 inches apart.*

Following your chalk line, lay out all floor channel for the exhaust chamber and all the walls. As you attach the wall panels together, they will also bolt to the floor channel.

Starting with the exhaust chamber at either rear corner, bolt one corner panel and one rear wall corner panel together. Bolt opposite rear sidewall panel to rear wall panel. Bolt all rear wall panels in place. Once you have assembled the rear and sidewalls of the chamber, bolt the tie channel along the top edge of these panels.

Place exhaust fan panel above the side and rear wall panels and bolt in place. Bolt (sandwich) filter filler panels between the sidewall and roof panels and the exhaust chamber.

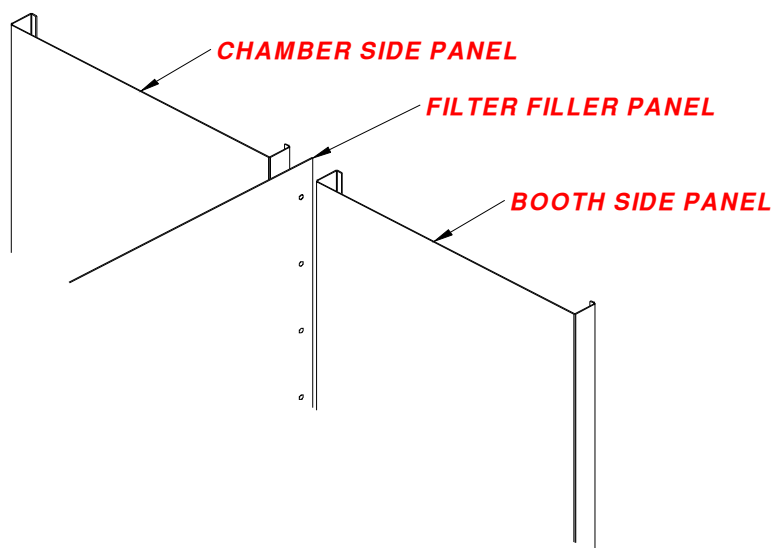

Following the exploded view drawings, continue alternately assembling wall panels and roof panels to each other until you reach the front end of the booth. Finish off the roof section by attaching the fire curtain if needed. If booth has doors, no fire curtain is needed.

While assembling the work area of the booth, if an I-Beam is encountered, make sure the booth has been assembled accurately before anchoring.

Roof and gabled ends should be installed so the rest of the booth can support them.

The remaining bolts that are not tight should be tightened now. Be sure the walls are plumb and true to your chalk-line before tightening. ALL bolts should be double checked to ensure that the main structure is tightly assembled.

Caulk all panel joints inside the booth with the caulk provided. Note: do not use a silicone caulk as this can cause finishing problems later.

If your booth is supplied with a Personnel Door or Front Filter Doors, apply foam gasket to perimeter of all door openings. Attach all door hardware and adjust latches. Level door with doors off, then re-attach doors to hinges.

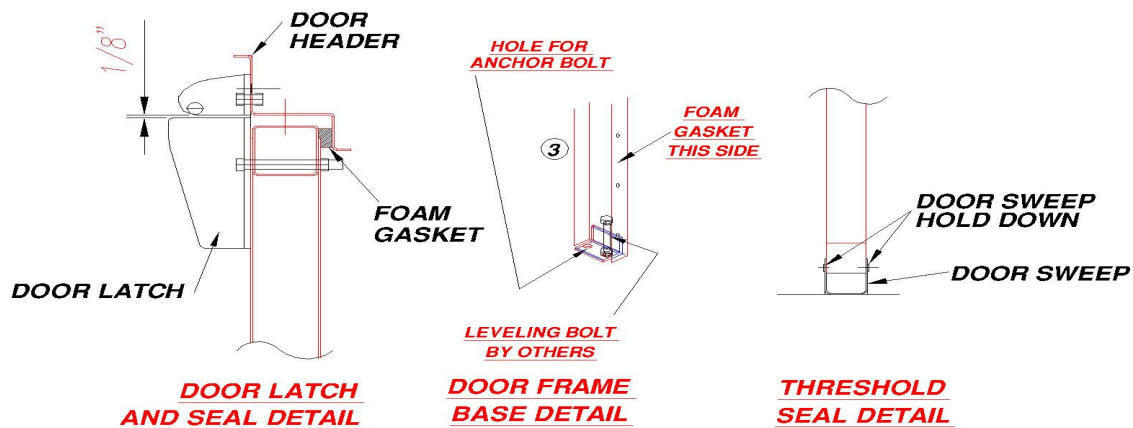

Light installation

Most industrial booths are supplied with a Class I Division II light fixture that bolts in place. If your booth is supplied with open-type light fixture, apply foam gasket material around all window frame openings. Place glass against the gasket, then place the light fixture over the glass and use the provided springs to secure the fixture. (It is best to have assistance with this procedure). The bulbs



required for the fixtures are T-8 (32watts).

The fan and motor assembly will bolt to the exhaust roof panel. Use the fan as a template and drill 3/8" diameter holes corresponding with the fan flange to attach the fan to the booth. Don't forget to install fan panel stiffeners (if they are supplied) after you know where to position your fan.

It is recommended that you have a licensed electrician wire the fan motor, air solenoid valve, and lights.

The Manometer is installed near the exhaust chamber. One side of the manometer tubing installs in the interior of the booth and the other tube installs in the exhaust chamber. Mount unit on the outside of exhaust chamber approximately 5' above floor level. Carefully read follow the installation instructions that come with the Manometer.

Initial calibration of manometer is made with booth totally shut down; adjust knob until gauge reads "0" inches. (Knob is on bottom left hand corner of manometer.) Install all new, clean exhaust filters; turn on all exhaust fans, close all doors and mark the gauge reading as "clean" (green arrow supplied with manometer), then turn exhaust fans off. Using cardboard, cover up every other

exhaust filter, until 50% of all exhaust filters are covered up. Turn on all exhaust fans, close all doors and mark the gauge reading as "replace filters" (red arrow supplied with manometer). This procedure simulates the filters loaded with paint, and establishes a base line for future filter replacement.

Exhaust filter installation.

Install one wire grid in each filter cell with the prongs facing into the booth; the exhaust filters will be attached to the prongs.

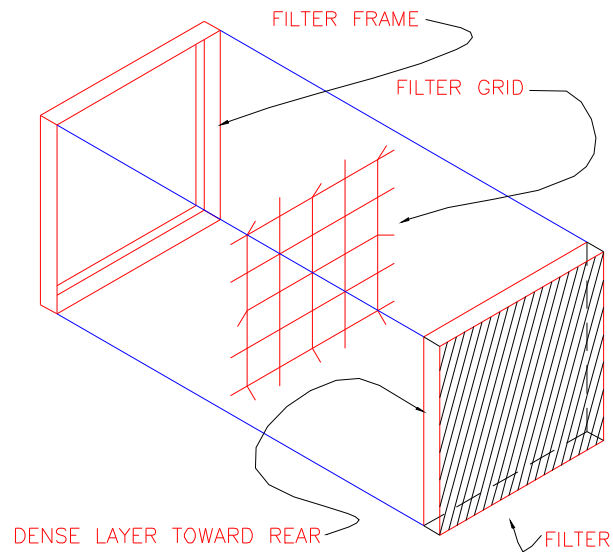

Intake filter installation.

If your booth has an intake plenum; simply insert the intake filter into the filter grid. The side that states "Air Leaving Side" on filter (tacky side) goes toward the inside of the booth.

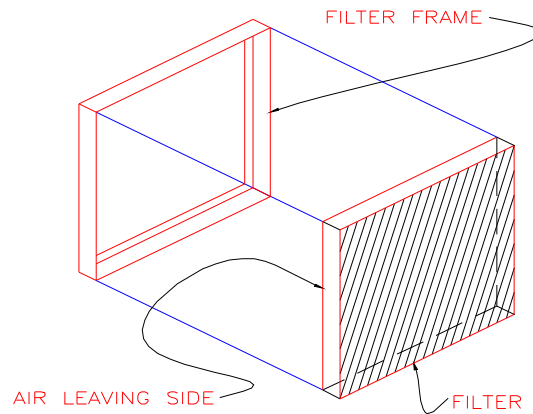

Exhaust duct.

If you purchased the optional exhaust ductwork; we suggest you have the flashing professionally installed as this entails cutting a hole in the roof of your building. To assemble the ductwork, first bolt the pipe with connecting ring to the exhaust fan, the rest of the ductwork is crimped on one end to interlock with the next section. Your ARV (Automatic Damper) will be mounted on top. The storm collar will attach to the duct above the flashing to make it weather proof.

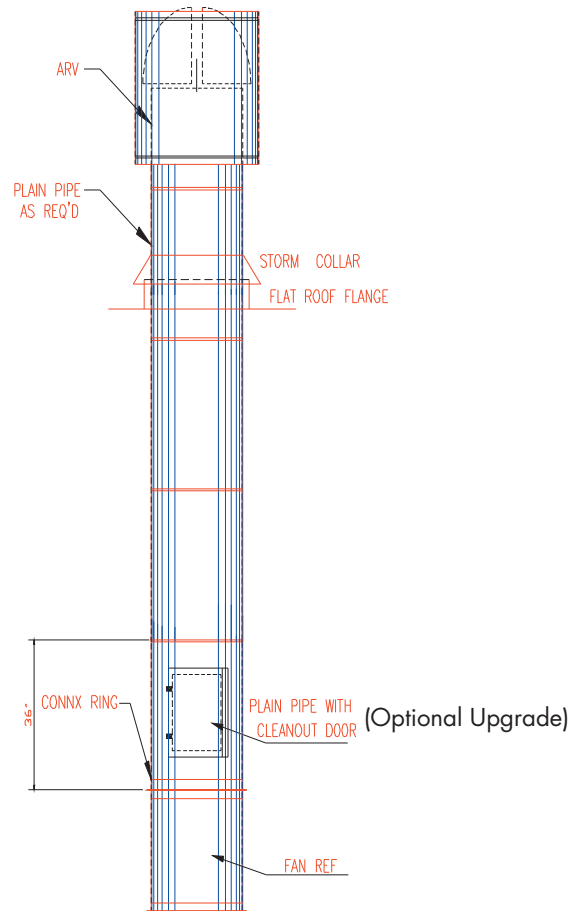

Where more than 25' of piping is required, the static pressure (resistance) is increased and the air flow may be hindered when using the standard exhaust unit recommended for use with the booth. Where a piping arrangement of an unusual nature is employed or where two or more elbows are used, a similar condition may exist. Therefore, if either of these situations arises, contact the booth manufacturer's engineering department for correct recommendations. We recommend exhaust piping, including the canopy (if used), should extend a minimum of 6' above the highest point of the building. There should be an access door just above the exhaust unit and another just below each elbow.

Check the following items prior to start up:

- 1.) Motors wired for proper voltage.
- 2.) All fans and motors turn freely.
- 3.) Lubricate all bearings. (Motor, Fan etc...)
- 4.) Check installation of exhaust fan for proper airflow direction. Generally airflow is out of booth.

- 5.) Listen for excessive or unusual noise when booth is operating.
- 6.) With booth operating, turn off the exhaust fan and mark sure that the air to the paint gun shuts off. This will verify proper safety operation of the booth.

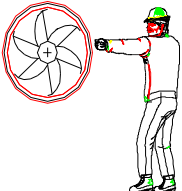
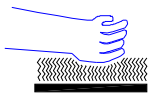
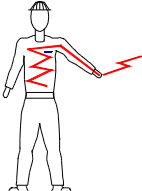
<u>AREA</u> <i>Indicates where hazards can occur.</i>	<u>Hazard</u> <i>Indicates what can happen if precautions are not observed.</i>	<u>Safeguards</u> <i>Indicates how to avoid the hazard and what special protective clothing, equipment and precautions will be used</i>
<u>MOVING PARTS</u> 	<i>Loose items, or parts of the body may get caught and cause serious injury or damage.</i>	<i>Keep hands and all items away from the fan blades. A guard is NOT placed over the fan housing. A mesh type guard will act as an accumulation point for combustible residues and become a fire hazard.</i>
<u>HOT PARTS</u> 	<i>Motors get hot when running. Serious burns may result if touched.</i>	<i>Never touch the motor during, or immediately after operation of the fan.</i>
<u>ELECTRICAL HAZARD</u> 	<i>Electrical currents can cause serious injuries.</i>	<i>Always turn electricity OFF before attempting repair or maintenance of the fan or motor.</i>