



ATD-10556 & ATD-10558 Bench Grinder Instruction Manual



3168328
Conforms to UL STD.NO.987
Certified to CAN/CSA STD.C22.2 NO.71.2

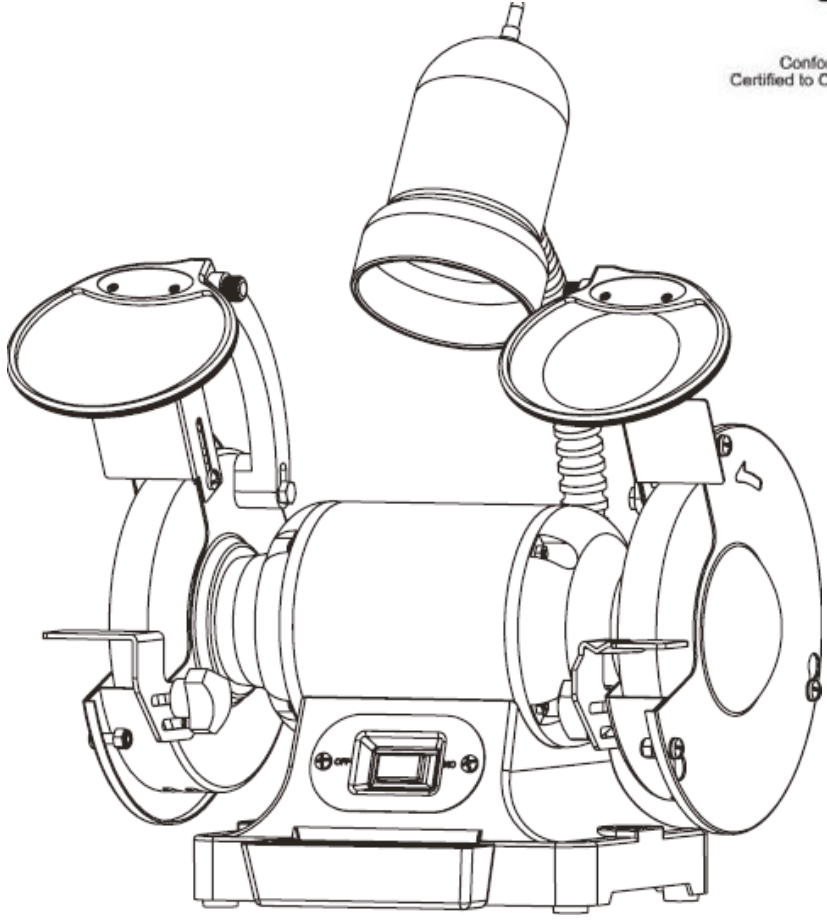

Table of Contents

SPECIFICATIONS -----	2
IMPORTANT SAFETY RULES-----	3
KNOW YOUR BENCH GRINDER -----	4
OPERATING INSTRUCTIONS-----	5-10
MAINTENANCE -----	11
TROUBLESHOOTING -----	12-13
EXPLODED VIEW AND PARTS LIST-----	14,15
WARRANTY -----	16

Specifications

Model #	ATD-10556
Serial #:	
Motor Type:	Induction
Motor Ratings:	120 V AC, 2.8 A, 60 Hz
Horsepower:	1/2 HP

Wheel Diameter:	6" (15 cm)
Wheel Width:	3/4" (20 mm)
Arbor Hole:	1/2" (13 mm)
No load Speed:	3450 RPM
Wheel Grits:	36 (Coarse) 60 (Medium)

Model #	ATD-10558
Serial #:	
Motor Type:	Induction
Motor Ratings:	120 V AC, 4.8 A, 60 Hz
Horsepower:	3/4 HP

Wheel Diameter:	8" (20 cm)
Wheel Width:	1" (25.4 mm)
Arbor Hole:	5/8" (16 mm)
No load Speed:	3450 RPM
Wheel Grits:	36 (Coarse) 60 (Medium)

Important Safety Rules

DANGER!! Failure to observe any of the following instructions could result in severe personal injury to tool user and bystanders or cause damage to tool and property!

WARNING! – Read, understand and observe all instructions in this manual before using or operating the tool for which it is written and supplied. Ensure that anyone who is to use the tool has read and understood the instructions provided.

- **Always** wear eye protection that complies with a recognized standard (CSA or ANSI).
- Wear a mask or respirator when dust is generated.
- Keep bystanders out of the work area while operating the tool.
- **WARNING! Always ensure that the work area is clear of any flammable materials, liquids or gasses, because the use of this tool may create sparks.**
- Tighten grinding wheel lock nuts, securing bolts and all clamps and guards.
- During each start-up, stand to one side of the grinder and switch it „On“. Let the grinder operate at full speed for approximately one minute so that any undetected flaws or cracks will become apparent.
- Keep guards in place and working properly.
- Keep hands clear of grinding wheels.
- **Never** reach behind or beneath the grinding wheels.
- Unplug from power supply before adjusting or servicing. The grinding wheels continue to rotate after the tool is switched off. Always allow wheels to stop before adjusting or servicing.
- To avoid electric shock, **DO NOT** use in damp conditions or expose to rain.
- When fitting a new grinding wheel, **always** check that the stated maximum RPM meets or exceeds that stated on the grinder. Also check the new wheel for damage, such as flaws or cracks. If the wheel appears satisfactory, fit it to the grinder.
- When a new grinding wheel has been fitted, stand to one side of the grinder and switch it „On“. Let the grinder operate at full speed for approximately one minute so that any undetected flaws or cracks will become apparent.
- Use only accessories that are recommended by the manufacturer for your model.
- **DO NOT** attempt to cut anything with the grinding wheel.
- Grounded tools must be plugged into an outlet that has been properly installed and grounded in accordance with all local codes and ordinances. Never remove the grounding prong from the plug or modify it in any way. Do not use adaptor plugs. If in doubt as to whether the outlet is properly grounded, consult a qualified electrician.
- Do not use the tool when tired or under the influence of drugs, alcohol or medication.
- Do not wear loose clothing or jewelery. Keep hair tied back.
- Ensure the power switch is off prior to plugging in the tool.

- **WARNING! Replace cracked grinding wheels immediately.**
- **Do not overtighten spindle nuts.**
- **Adjust tool rests whenever necessary to maintain a distance of 1/8" (3.2 mm) from the grinding wheel.**

- Service on these tools should only be performed by an authorized, qualified technician.

- Know Your Grinder

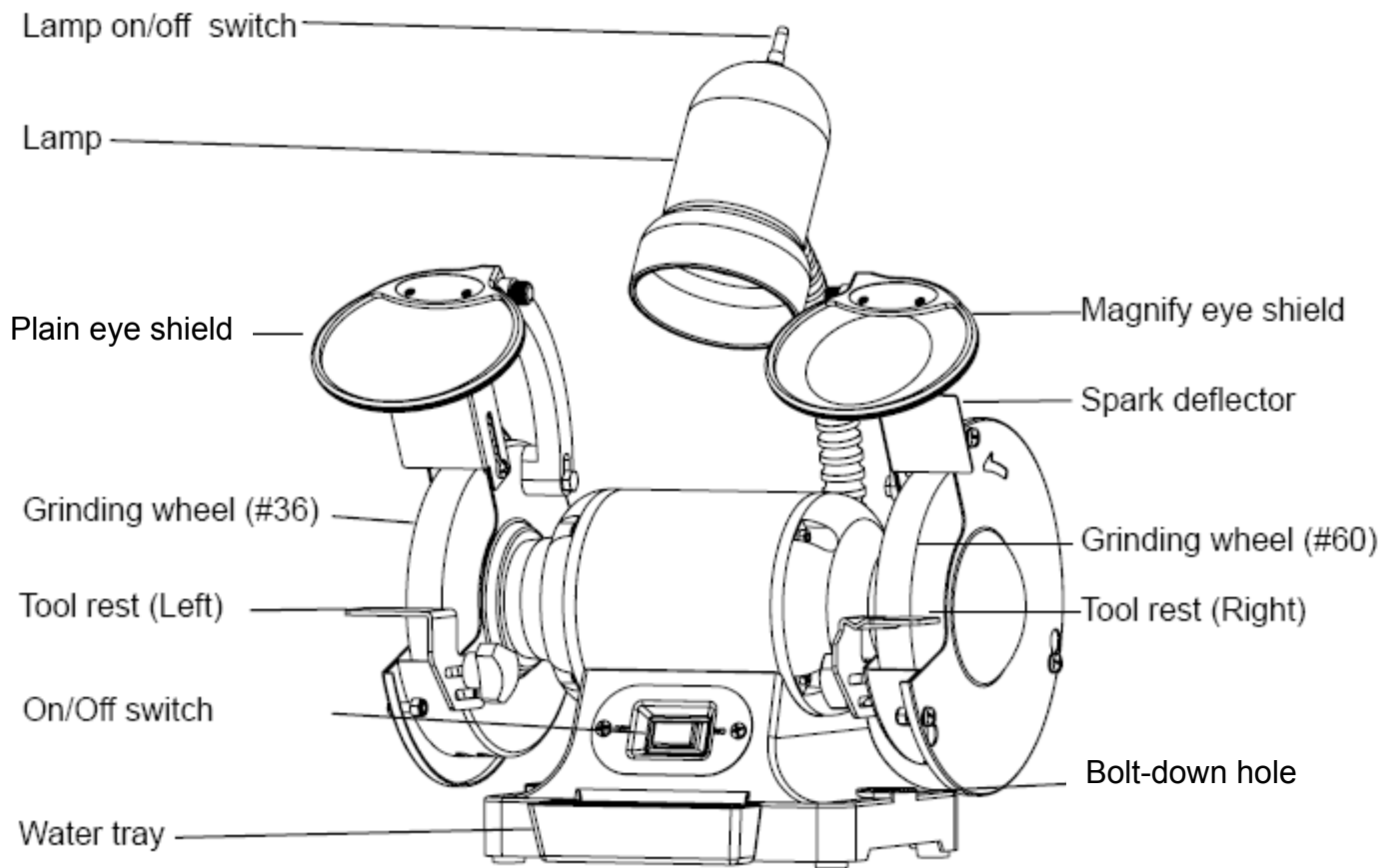

Operating Instructions

Before You Start - Safety

- **Always** wear eye protection that complies with a recognized standard (for example: ANSI Z87.1) - (CSA or ANSI).
- Wear a mask or respirator when dust is generated.
- Keep bystanders out of the work area while operating the tool.
- **WARNING! Always ensure that the work area is clear of any flammable materials, liquids or gasses, because the use of this tool may create sparks.**
- Do not wear loose clothing or jewellery. Keep hair tied back.
- **WARNING! Replace cracked grinding wheels immediately.**
- **Do not overtighten spindle nuts.**
- Adjust tool rests whenever necessary to maintain a distance of 1/8" (3.2 mm) from the **grinding wheel.**
- NEVER grind on the side of the wheel. Grind on the face of the wheel only.
- NEVER apply pressure to the workpiece when the grinding wheel is cold. Allow the wheel to warm up by applying the workpiece gradually.
- NEVER use the grinder without the wheel guards. Keep thumbs and fingers away from the wheel.

Before You Start – Electrical

In the event of a malfunction or short circuit, grounding provides the path of least resistance for electrical current, and reduces the risk of electric shock for the operator. This tool is equipped with an electric cord that has an equipment grounding conductor and a grounding plug. The plug **MUST** be plugged into a matching outlet that is properly installed and grounded in accordance with ALL local codes and ordinances.

DO NOT MODIFY THE PLUG PROVIDED. If it will not fit the outlet, have the proper outlet installed by an electrician.

Figure 2

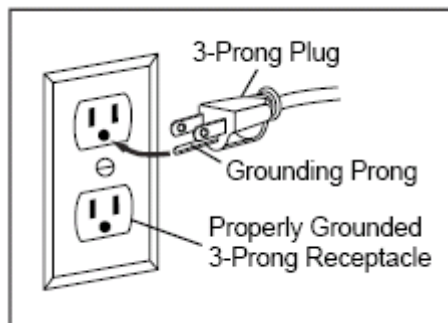

IMPROPER CONNECTION of the equipment grounding conductor can result in increased risk of electric shock. The conductor with the green insulation (with or without yellow stripes) is the equipment grounding conductor. If repair or replacement of the electric cord or plug is necessary, **DO NOT** connect the equipment grounding conductor to a live terminal.

CHECK with a qualified electrician or service personnel if you do not completely understand the grounding instructions, or if you are not sure if the tool is properly grounded.

This tool is intended for use on a circuit that has an outlet that looks like the one illustrated. The original tool has a grounding plug that looks like the plug illustrated (Figure 2).

Use of Extension Cords

USE ONLY THREE-WIRED EXTENSION CORDS that have 3-pronged plugs and 3-holed outlets that accept the tool's plug. Repair or replace damaged or worn cords immediately.

Be sure your extension cord is properly wired and in good condition. Do not use damaged extension cords. Always replace a damaged extension cord.

When using an extension cord, be sure to use one heavy enough to carry the current your product will draw. An undersized cord will cause a drop in line voltage, resulting in loss of power and overheating. The table below shows the correct size to use according to the cord length and the amperage draw of the tool (specified on the nameplate). When in doubt, use the next heavier gauge. The smaller the gauge number, the heavier the cord. (AWG = American Wire Gauge).

Minimum Gauge for Extension Cords (AWG)
(when using 120 volts only)

Ampere Rating		Total Length of Cord in Feet (meters)			
More Than	Not more Than	25' (7.6m)	50' (15m)	100' (30.4m)	150' (45.7m)
0	6	18	16	16	14
6	10	18	16	14	12
10	12	16	16	14	12
12	16	14	12	Not Recommended	

Use a separate electrical circuit for your tools. This circuit should not be less than a #12 gauge wire, and should be protected with a 15 A time-lag fuse. Before connecting the motor to the power line, ensure the switch is in the OFF position and the electric current is rated the same as the current stamped on the motor's nameplate. Running at a lower voltage will damage the motor and is not covered by warranty.

Before You Start – Package Contents

Left work rest-----	1
Right work rest-----	1
Plain eye shield-----	1
Magnifying eye shield-----	1
Eye shield adjusting knob -----	2
Eye shield mounting rod – one left, one right	
Eye shield assembly mounting bolt M6x30-----	2
Eye shield assembly mounting washer D6-----	2
Eye shield assembly mounting locking washer D6-----	2
Work rest fixing knob-----	2
Work rest plain washer D5 -----	2
Work rest lock washer D5 -----	2
Coolant tray-----	1
Spark deflector-----	2
Spark deflector adjusting screw assembly -----	2

Before You Start – Assembly and Installation

Mounting the Grinder to the Workbench

Before attempting to use this grinder, it must be properly mounted to a workbench or grinding stand (ATD-10557).

CAUTION! Bench grinders vibrate. Grinder movement during high-speed rotation may cause injury or damage to the workpiece or operator. Mount the grinder securely to a sturdy workbench or grinding stand.

1. Position the grinder on the workbench.
2. Mark the workbench through the two mounting holes located in the grinder base.
3. Drill holes in the workbench at the marks.
4. Using two long bolts, washers, lock-washers and nuts, as shown (not supplied), secure the grinder to the workbench.

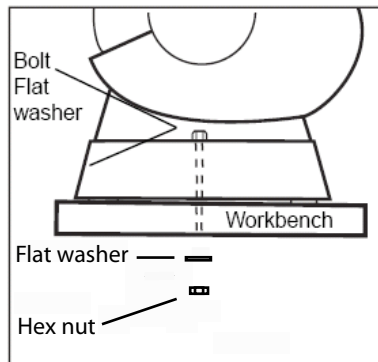

Eye Shield Installation

Eye shields must be installed before operating the bench grinder.

1. Mount the left and right shield rods to the inside of the wheel guards using hex bolts.

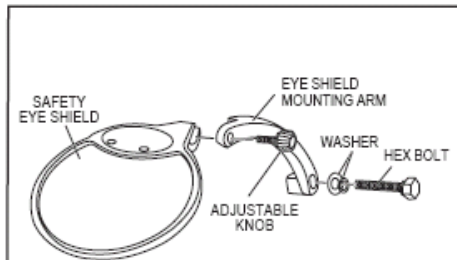

2. Once shield rods are firmly in place, slide the shield bracket onto the shield rod.

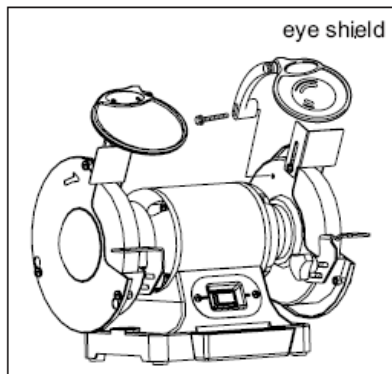

3. Tighten the carriage bolt, leaving it loose enough to allow the safety shield to be raised and lowered easily

NOTE: The eye shield should move freely when being adjusted, but stay in place when the locking knob is tightened.

WARNING! Turn the power off and remove the plug from the outlet before changing the grinding wheels. When turning the grinder on with a newly installed wheel, **DO NOT STAND IN FRONT OF THE GRINDER.** Stand to the side and allow the grinder to run for at least one minute before proceeding to use it.

Installing or Changing the Wheel

1. Use a screwdriver to loosen the wheel cover screws and push counter-clockwise to remove the wheel cover.
2. Fit an appropriately sized wrench on the spindle hex nut.
3. Loosen the wheel nut in a clockwise direction for the left side and a counter-clockwise direction for the right side.
4. Remove the outer flange and grinding wheel. To remove the hex nut, turn the wrench and nut until the wrench is resting on the workbench behind the tool.
5. Inspect the new wheel carefully to ensure there are no cracks, chips or other damage.
6. Wipe the flange surfaces clean, and install the new wheel, flange and the spindle hex nut.
7. To install a new grinding wheel, reverse the above procedure.
8. Be sure the grinding wheel and outer flange are properly seated on the spindle shaft.
9. Replace the wheel cover and reposition the tool rest.

When turning the grinder on with a newly installed wheel, DO NOT STAND IN FRONT OF THE GRINDER. Stand to the side and allow the grinder to run for at least one minute before proceeding to use it.

IMPORTANT! Do not overtighten the spindle hex nut, because this may cause the wheel to crack.

CAUTION! DO NOT INSTALL OR USE A DAMAGED GRINDING WHEEL. The force of rotation may cause a damaged wheel to fly apart, and could injure operators or bystanders.

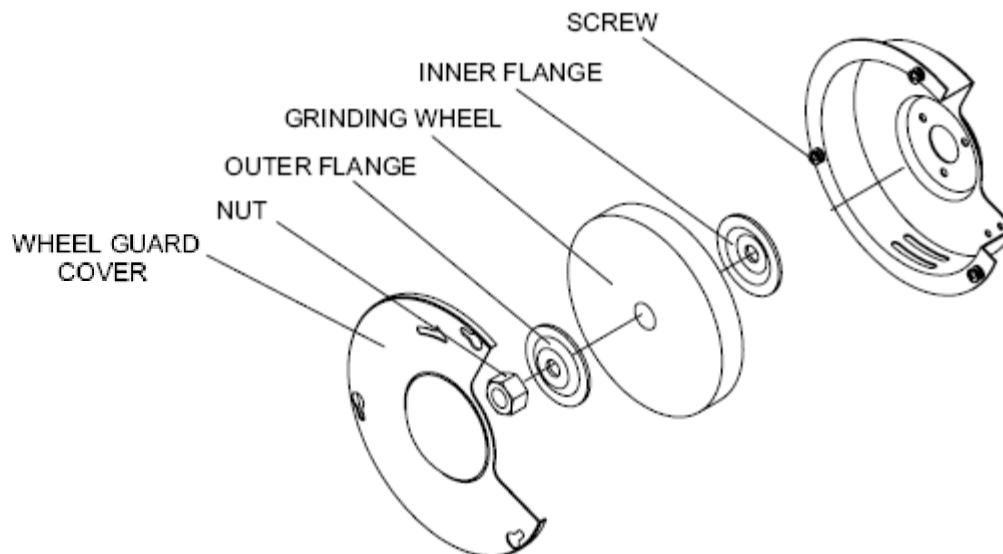

Tool Rest Adjustments and Installation

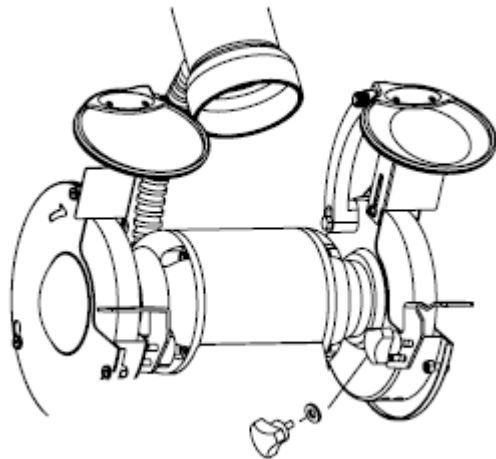

Mount the tool rests to the work rest bracket using the knob and washers.

Before tightening the knob, adjust the gap between the grinding wheel and the work rest to a maximum of 1/8" (3.2 mm). Tighten securely.

Adjustments

To prevent the workpiece from being pulled and caught between the tool rest and the wheel, readjust the tool rest position whenever necessary to maintain the 1/8" (3.2 mm) distance.

1. Loosen, but do not remove, the knob holding the tool rest arm.
2. Slide the tool rest in or out to achieve a 1/8" (3.2 mm) distance from the grinding wheel surface.
3. Re-tighten the lock knob.

Using Your Bench Grinder

This 8" Bench Grinder is ideal for use in sharpening chisels, axes and other wood-cutting tools. It is also useful for repairing tips on screwdrivers and drill bits or for removing excess metal burrs from pieces of cut metal.

With the proper accessories, this tool can be used for cleaning metal surfaces using a wire brush or for buffing and polishing using a cloth wheel.

ON/OFF

The rocker ON/OFF power switch is located on the front of the grinder.

1. Press the side marked ON to turn the grinder on.
2. Press the side marked OFF to turn the grinder off.

Grinding

- Adjust the tool rest to accommodate large or unusually shaped workpieces.
- Always keep the workpiece moving across the face of the grinding wheel. Grinding continuously on the same spot on the wheel will cause grooves to be worn into the wheel. The wheel may crack or become damaged more easily, and grinding of other objects will be difficult.
- If the workpiece becomes hot, dip it into the water or oil to cool it.
- Always grind on the face of the wheel (around the diameter), NEVER on the sides. Side pressure on grinding wheels can cause cracking and damage.

- If the face of the grinding wheel is worn unevenly, becomes grooved, or is no longer smooth and flat, the wheel should be reshaped with a dressing tool (not supplied).
- If the diameter of the grinding wheel is no longer round, the wheel should be reshaped with a dressing tool or replaced.
- If the surface of the wheel becomes loaded and dull with workpiece material, the wheel should be cleaned with a dressing tool.
- After reshaping, always readjust the tool rests and spark arrestors.

Maintenance

Maintenance Required

1. Check power cord
2. Check wheels for cracks
3. Check moving parts for alignment and binding issues
4. Dress Grinding Wheels
5. Replace Grinding Wheels (see manual section for specifics)
6. Clean and vacuum dust from the motor housing and other grinder parts
7. Replace work-light bulb

Frequency

- Before each use.
 Before each use.
 Before each use.
 As needed
 As needed.
 As needed.
 As needed

Service beyond recommended maintenance on these tools should only be performed by an authorized, qualified technician.

COOLANT TRAY

When grinding, metal objects become heated quickly. It is important to keep moving the object back and forth across the face of the grinding wheel and to cool the object frequently using the coolant tray.

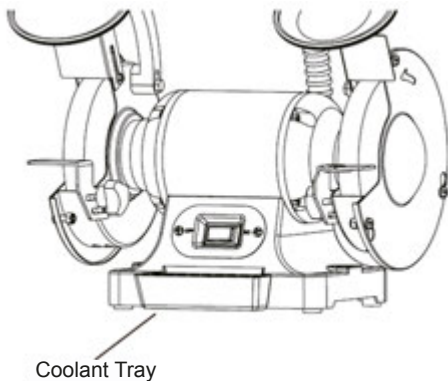

WORK-LIGHT BULB REPLACEMENT

Use Max 40 W anti-vibration light bulb

Troubleshooting

Service on these tools should only be performed by an authorized, qualified technician.

SYMPTOM	PROBABLE CAUSE	CORRECTIVE ACTION
Motor will not start.	<ol style="list-style-type: none"> 1. Low Voltage. 2. Open circuit in motor or loose connections. 3. Blown fuse or breaker. 	<ol style="list-style-type: none"> 1. Check power source for proper voltage. 2. Inspect all lead connection on motor for loose or open connections. (Send for Servicing.) 3. Short circuit. (Send for Servicing.) 4. Improper match between tool and circuit, fuse or breaker.
Motor will not start – fuses or circuit breakers tripping or blowing.	<ol style="list-style-type: none"> 1. Short circuit in line, cord or plug. 2. Short circuit in motor or loose connections. 3. Incorrect fuses or circuit breakers in power line. 	<ol style="list-style-type: none"> 1. Inspect cord or plug for damaged insulation and shorted wires. 2. Inspect all connections on motor for loose or shorted terminals and/or worn insulation. 3. Install correct fuses or circuit breakers or switch tool to an appropriately sized circuit.
Motor overheats.	<ol style="list-style-type: none"> 1. Motor overloaded. 2. Extension cord too long and of insufficient gauge (weight). 	<ol style="list-style-type: none"> 1. Reduce load on motor. 2. Utilize an extension cord of appropriate gauge and length or plug tool directly into outlet.
Motor stalls (resulting in blown fuses or tripped circuit).	<ol style="list-style-type: none"> 1. Short circuit in motor or loose connections. 2. Low voltage. 3. Incorrect fuses or circuit breakers in power line. 4. Motor overload. 	<ol style="list-style-type: none"> 1. Inspect connections on motor for loose or shorted terminals or worn insulation. (Send for Servicing.) 2. Correct low voltage conditions (for example: improper extension cord length and/or gauge). 3. Install correct fuses or circuit breakers or plug tool into an appropriate circuit, matched to an appropriate fuse or breaker. 4. Reduce the load on the motor.
Machine slows when operating.	<ol style="list-style-type: none"> 1. Feed rate too great. 	<ol style="list-style-type: none"> 1. Reduce the rate at which the workpiece is fed into the working area of the tool (grinding wheel).

Wavy condition on surface of workpiece.	<ol style="list-style-type: none"> 1. Machine vibrating. 2. Workpiece not being held firmly. 3. Wheel face uneven. 4. Wheel is too hard. 	<ol style="list-style-type: none"> 1. Ensure machine is securely mounted on a solid surface. 2. Use a holding device to firmly retain the workpiece. 3. Dress the grinding wheel. 4. Use softer wheel, or reduce the feed rate.
Lines on surface of workpiece.	<ol style="list-style-type: none"> 1. Impurity on surface of wheel. 2. Workpiece not being held tightly. 	<ol style="list-style-type: none"> 1. Dress the grinding wheel. 2. Use a holding device to more firmly retain the workpiece.
Burning spots or cracks in the workpiece.	<ol style="list-style-type: none"> 1. Improper type of grinding wheel. 2. Improper feed rate. 3. Coolant required. 	<ol style="list-style-type: none"> 1. Try wheels with softer bond or coarser grit. 2. Slow down the rate at which the workpiece is fed into the wheel. 3. Introduce coolant.
Wheel dulls quickly, grit falls off.	<ol style="list-style-type: none"> 1. Feed rate is too aggressive. 2. Wheel is soft. 3. Wheel diameter too small. 4. Bad wheel dressing. 5. Defective wheel bonding. 	<ol style="list-style-type: none"> 1. Decrease feed rate of workpiece into grinding wheel. 2. Select a grinding wheel with a harder bond of material. 3. Replace wheel. 4. Dress the wheel. 5. DO NOT USE – return wheel to point of purchase.
Wheel clogs and workpiece shows burn marks.	<ol style="list-style-type: none"> 1. Wheel is too hard. 2. Feed rate is too slow. 3. Bad wheel dressing. 4. Coolant required. 	<ol style="list-style-type: none"> 1. Select a grinding wheel with a softer bond of material. 2. Increase the feed rate of the workpiece into the grinding wheel. 3. Dress the wheel. 4. Introduce coolant.

ATD-10556 - 6" GRINDER PARTS DIAGRAM

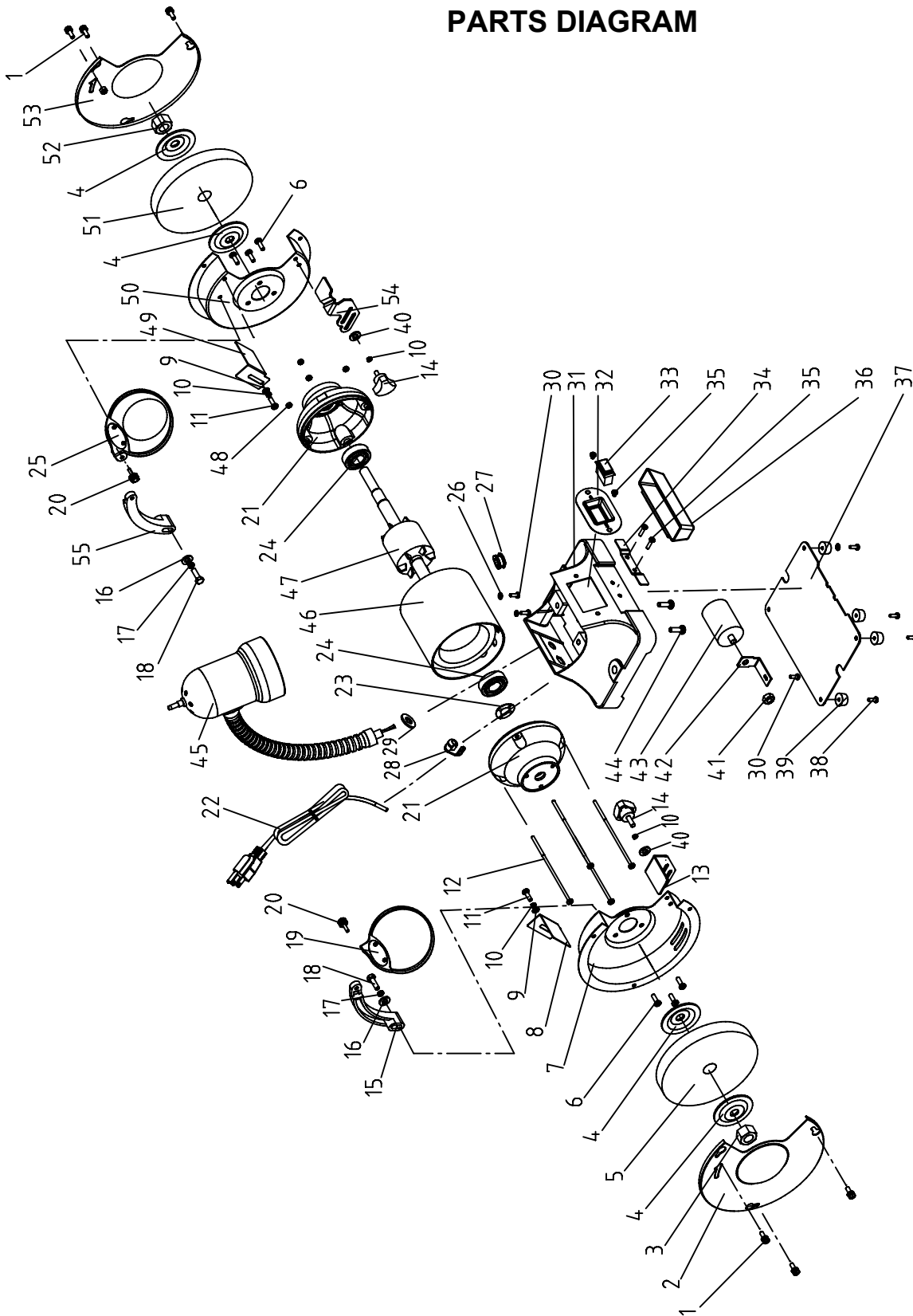

ATD-10556

ITEM#	ORDERING PART#	DESCRIPTION	SPEC	QTY
1	PRT10556-01	PHILIPS SCREW +SPRING WASHER+FLAT WASHER (BLACK)	M5x12	6
2	PRT10556-02	LEFT WHEEL COVER		1
3	PRT10556-03	HEX NUT (WHITE)	M12 Left	1
4	PRT10556-04	FLANGE (WHITE)		4
5	ATD-10552	6" WHEEL COARSE (Φ150x20xΦ12.7)	36#	1
6	PRT10556-06	PHILIPS SCREW +SPRING WASHER (WHITE)	M5x10	6
7	PRT10556-07	LEFT GUARD COVER PLATE ASSY		1
8	PRT10556-08	LEFT SPARK DEFLECTOR		1
9	PRT10556-09	FLAT WASHER (BLACK)	D5	2
10	PRT10556-10	SPRING WASHER (BLACK)	D5	4
11	PRT10556-11	PHILIPS SCREW (BLACK)	M5x8	2
12	PRT10556-12	PHILIPS SCREW +FLAT WASHER (WHITE)	M4x135	4
13	PRT10556-13	LEFT TOOL REST		1
14	PRT10556-14	LOCKING KNOB	M5x10	2
15	PRT10556-15	LEFT EYESHIELD BRACKET		1
16	PRT10556-16	FLAT WASHER (BLACK)	D6	2
17	PRT10556-17	SPRING WASHER (BLACK)	D6	2
18	PRT10556-18	HEX BOLT (BLACK)	M6x30	2
19	PRT10556-19	LEFT EYESHIELD ASSY		1
20	PRT10556-20	EYESHIELD LOCKING KNOB	M4	2
21	PRT10556-21	END BELL		2
22	PRT10556-22	POWER CORD		1
23	PRT10556-23	WAVE WASHER	D35	1
24	PRT10556-24	BEARING 6202RZ		2
25	PRT10556-25	MAGNIFIED EYESHIELD		1
26	PRT10556-26	OUTER TOOTHED LOCKING WASHER	D4	2
27	PRT10556-27	CORD BUSHING		1
28	PRT10556-28	CORD CLIP (6P4)		1

ITEM#	ORDERING PART#	DESCRIPTION	SPEC	QTY
29	PRT10556-29	FLAT WASHER (WHITE)	D12	1
30	PRT10556-30	PHILIPS SCREW + SPRING WASHER+FLAT WASHER	M4x8	3
31	PRT10556-31	BASE		1
32	PRT10556-32	SWITCH PLATE		1
33	PRT10556-33	ROCKER SWITCH		1
34	PRT10556-34	COOLANT TRAY CLIP		1
35	PRT10556-35	PHILIPS SCREW (BLACK)	M4x8	4
36	PRT10556-36	COOLANT TRAY		1
37	PRT10556-37	BASE PLATE		1
38	PRT10556-38	PHILIPS SCREW + BIG FLAT WASHER (WHITE)	M4x12	4
39	PRT10556-39	RUBBER FOOT		4
40	PRT10556-40	BIG FLAT WASHER (BLACK)	D5	2
41	PRT10556-41	HEX NUT, I TYPE (WHITE)	M8	1
42	PRT10556-42	CAPACITOR SUPPORT		1
43	PRT10556-43	CAPACITOR 8MF300V		1
44	PRT10556-44	PHILIPS SCREW +SPRING WASHER (WHITE)	M6x18	2
45	PRT10556-45	LAMP ASSY		1
46	PRT10556-46	STATOR		1
47	PRT10556-47	ROTOR		1
48	PRT10556-48	HEX NUT (WHITE)	M4	4
49	PRT10556-49	RIGHT SPARK DEFLECTOR		1
50	PRT10556-50	RIGHT GUARD COVER PLATE ASSY		1
51	ATD-10551	6" WHEEL MEDIUM (Φ150x20xΦ12.7)	60#	1
52	PRT10556-52	HEX NUT, I TYPE(WHITE)	M12	1
53	PRT10556-53	RIGHT WHEEL COVER		1
54	PRT10556-54	RIGHT TOOL REST		1
55	PRT10556-55	RIGHT EYESHIELD BRACKET		1

ATD-10558 - 8" GRINDER PARTS DIAGRAM

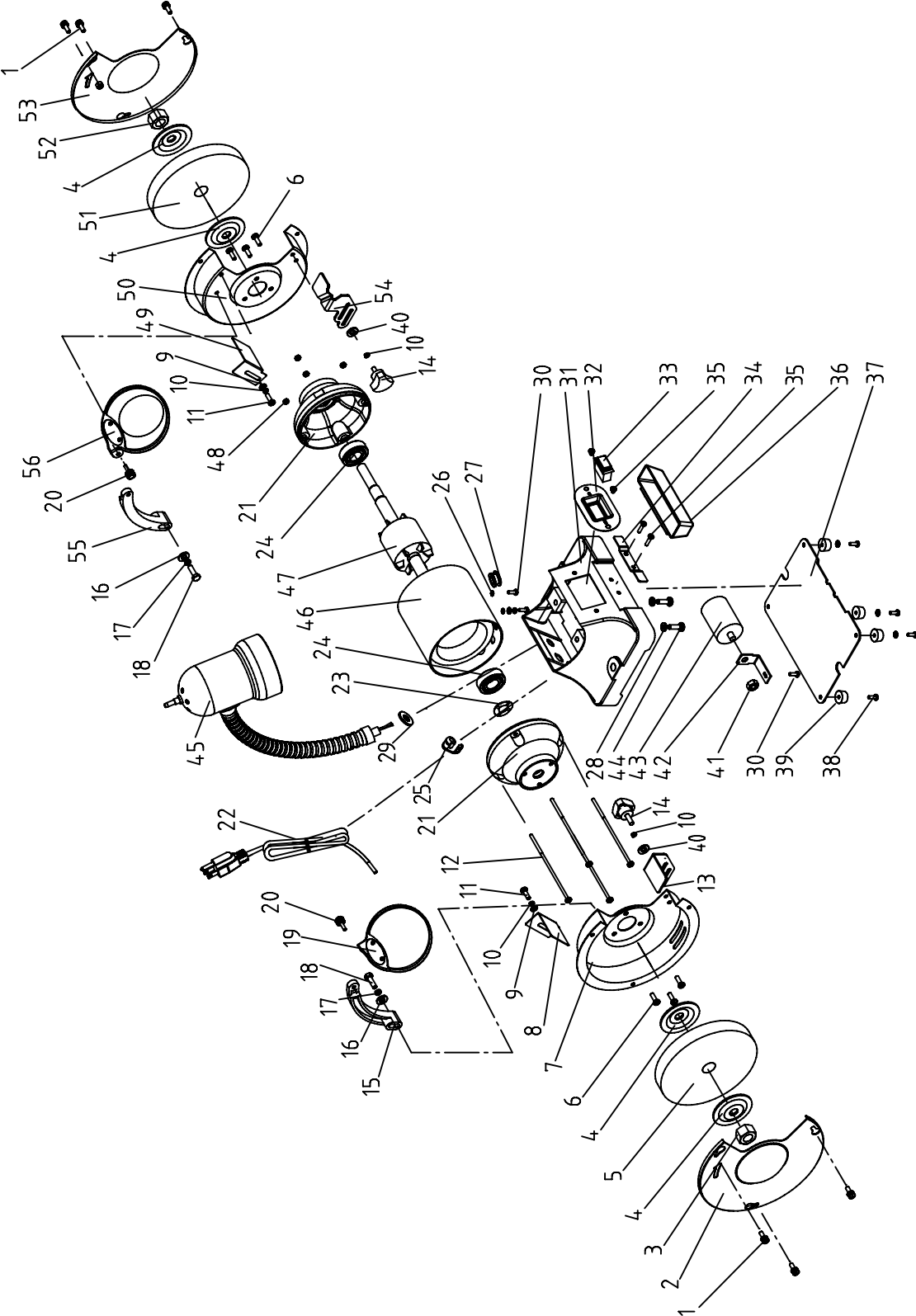

ATD-10558

ITEM#	ORDERING PART#	DESCRIPTION	SPEC	QTY	ITEM#	ORDERING PART#	DESCRIPTION	SPEC	QTY
1	PRT10556-01	PHILIPS SCREW +SPRING WASHER+FLAT WASHER(BLACK)	M5X12	6	29	PRT10556-29	FLAT WASHER	D12	1
2	PRT10558-02	LEFT WHEEL COVER		1	30	PRT10556-30	PHILIPS SCREW +SPRING WASHER+FLAT WASHER	M4X8	3
3	PRT10558-03	HEX NUT (WHITE)	M16 LEFT	1	31	PRT10558-31	BASE		1
4	PRT10558-04	FLANGE (WHITE)		4	32	PRT10556-32	SWITCH PLATE		1
5	ATD-10554	8" WHEEL COARSE (Ø200×25×Ø15.88)	36#	1	33	PRT10556-33	ROCKER SWITCH		1
6	PRT10556-06	PHILIPS SCREW +SPRING WASHER(WHITE)	M5X10	6	34	PRT10556-34	COOLANT TRAY CLIP		1
7	PRT10558-07	LEFT GUARD COVER PLATE ASSY		1	35	PRT10556-35	PHILIPS SCREW (BLACK)	M4X8	4
8	PRT10556-08	LEFT SPARK DEFLECTOR		1	36	PRT10556-36	COOLANT TRAY		1
9	PRT10556-09	FLAT WASHER (BLACK)	D5	2	37	PRT10558-37	BASE PLATE		1
10	PRT10556-10	SPRING WASHER (BLACK)	D5	4	38	PRT10558-38	PHILIPS SCREW +BIG FLAT WASHER(WHITE)	M5x16	4
11	PRT10556-11	PHILIPS SCREW (BLACK)	M5X8	2	39	PRT10558-39	RUBBER FOOT		4
12	PRT10558-12	PHILIPS SCREW +FLAT WASHER(WHITE)	M5X155	4	40	PRT10556-40	BIG FLAT WASHER (BLACK)	D5	2
13	PRT10558-13	LEFT TOOL REST		1	41	PRT10556-41	HEX NUT, I TYPE(WHITE)	M8	1
14	PRT10556-14	LOCKING KNOB	M5X10	2	42	PRT10556-42	CAPACITOR SUPPORT		1
15	PRT10558-15	LEFT EYESHIELD BRACKET		1	43	PRT10558-43	CAPACITOR		1
16	PRT10556-16	FLAT WASHER (BLACK)	D6	2	44	PRT10558-44	HEX BOLT	M8x20	2
17	PRT10556-17	SPRING WASHER (BLACK)	D6	2	45	PRT10556-45	LAMP ASSY		1
18	PRT10556-18	HEX BOLT (BLACK)	M6X30	2	46	PRT10558-46	STATOR		1
19	PRT10556-19	LEFT EYESHIELD ASSY		1	47	PRT10558-47	ROTOR		1
20	PRT10556-20	EYESHIELD LOCKING KNOB	M4	2	48	PRT10558-48	HEX NUT(WHITE)	M5	4
21	PRT10558-21	END BELL		2	49	PRT10556-49	RIGHT SPARK DEFLECTOR		1
22	PRT10556-22	POWER CORD		1	50	PRT10558-50	RIGHT GUARD COVER PLATE ASSY		1
23	PRT10558-23	WAVE WASHER	D40	1	51	ATD-10553	8" WHEEL MEDIUM (Ø200×25×Ø15.88)	60#	1
24	PRT10558-24	BEARING 6203RZ		2	52	PRT10558-52	HEX NUT, I TYPE(WHITE)	M16	1
25	PRT10556-28	CORD CLIP (6P4)		1	53	PRT10558-53	RIGHT WHEEL COVER		1
26	PRT10556-26	OUTER TOOTHED LOCKING WASHER	D4	2	54	PRT10558-54	RIGHT TOOL REST		1
27	PRT10556-27	CORD BUSHING		1	55	PRT10556-55	RIGHT EYESHIELD BRACKET		1
28	PRT10558-28	SPRING WASHER (WHITE)	D8	2	56	PRT10556-25	MAGNIFIED EYESHIELD ASSY		1