



# **\*\* IMPORTANT \*\* BEFORE USING THE CYCLONE SHAKER**

**Unscrew the lubricator bowl from the shaker body by hand. Fill the lubricator bowl to the level mark using air tool oil provided. There may be a small amount of oil left in bottle.**

**Lack of lubrication will result in premature wear, loss of operation, and possibly void the warranty.**

***It is critical that the Cyclone Shaker is properly lubricated during every operation.***

**THANK YOU,  
DEDOES INDUSTRIES**

248-624-7710

[www.dedoes.com](http://www.dedoes.com)

## IMPORTANT

Read and follow these instructions carefully to ensure proper operation and warranty protection of your new paint shaker.

## WARRANTY

Dedoes warrants the Cyclone Paint Shaker against defects due to defective material, design or manufacturing to the end user for 3 years. The warranty covers all manufactured parts on the shaker that are defective or damaged. All products, goods, services and equipment comply with all applicable environmental, safety, design and regulatory laws, regulations, customs and requirements of the region in which they are delivered and put into service. This warranty does not cover any items that have been damaged due to mutilation, alteration, misuse or abuse. Corrosion due to neglect or chemicals is not covered by this warranty. Dedoes will not be responsible for loss of time, inconvenience or other consequential damages.

Warranty is void: if there is any lack of lubrication and/or poor maintenance in which has caused the operation of the shaker to fail, if Dedoes parts are not used for repairs or installation, and if shaker is not installed properly.

This is the only warranty on Dedoes products and no other expressed warranty by anyone other than Dedoes, in writing, will be binding on the manufacturer. This warranty is transferable from the location of the original installation of the shaker to any additional installation location within the warranty time period.

Warranty return policy: Under no circumstances should the shaker or any part there-of be returned to Dedoes for inspection, replacement, and/or repair without the written consent from Dedoes.

## WARNING

The Cyclone Shaker is approved for hazardous areas. This paint shaker is intended for use only by trained professionals in industrial work areas where public and incidental access is prohibited. The manufacturer prohibits the sale or use for other purposes.

Use a standard petroleum 10W non-detergent rust inhibiting air tool oil, such as Lubriplate Rockwell 10R, or other air tool oil recommended for all air cylinders and air tools. Do not use motor oil. The oil should have neither gum and varnish removers nor petroleum distillates. Never use silicone oils or grease in a paint shop. The clear plastic drip rate adjustment knob on the automatic lubricator may crack or break if exposed to certain solvents and synthetic oils. Do not operate the shaker on compressed nitrogen or other inert gases without positive ventilation of the work area.

## INSTALLATION

Bolt the pedestal securely to the floor and bolt the shaker to the pedestal. See page 11 for instructions and a template. The shaker may be bolted to a bench or table top, however, the bench must be rigid or it will shake apart. See page 12 for instructions and a template. Always seal the shaker housing to the pedestal or bench top with non-silicone elastomeric sealant to prevent leaking and greatly reduce noise.

Temporary or portable installations of the Shaker and Pedestal can be made by bolting the assembly to a 14 or 15 inch wheel and tire having a five-bolt mounting pattern on a 4.75 or 5 inch bolt circle. See page 11 for instructions and a template.

Mount the supplied lubricator to the shop air line and connect the shaker using a 1/4 inch (4 mm) inside diameter air hose that is no longer than four feet (1.2M). The hose must be rated for 200 PSI (1300 kPa) or higher working pressure. Avoid air line low spots to prevent water traps. Connect the shaker as shown by Option 1 below. Excessive moisture or any dirt in the airline must be prevented by installing an air filter as shown in Option 1. The lubricator may be mounted directly onto the shaker shown by Option 2 below. Install the lubricator with the arrow pointing toward the shaker in the direction of the air flow. Unscrew the lubricator bowl from the body. Fill the lubricator bowl with the supplied air tool oil to the fill line. Screw the bowl on straight to avoid cross threading. The seal ring on the bowl of the lubricator body must be installed correctly for the lubricator to work. Check that the drip rate adjustment knob is open and set to 4. Adjust the lubricator by turning the vertical line on the drip rate dial clockwise until it stops and then turning it counter clockwise to number 4. Install a quick connect in the air line upstream of the control valve to allow manual lubrication when needed. If manual lubrication is required, squirt a few drops of oil into the quick connect plug before each use.

### OPTION 1:

Lubricator mounted onto wall with air filter.

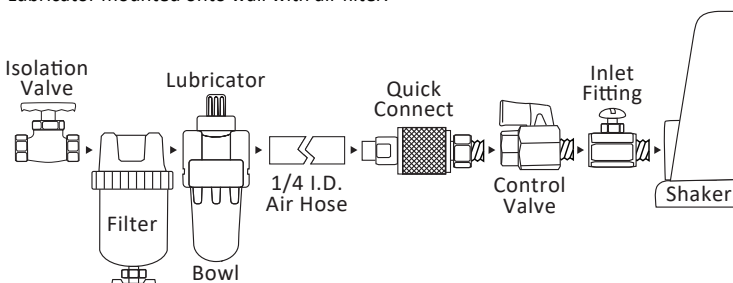

### OPTION 2:

Lubricator mounted directly onto the shaker

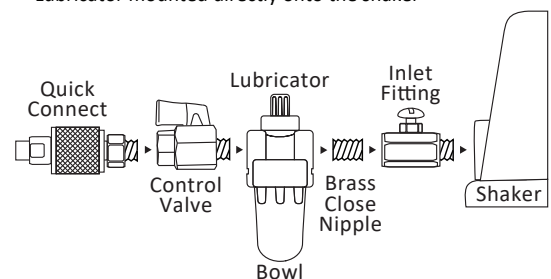



**ASSEMBLY NOTES:**

Item	PN#	Torque	Thread Lube	Notes
Piston Screw & Rod End	M-279 & M-286	20-25 ft-lb	Thread Lock*	Heat to 550°F to disassemble.
Relief Jam Nut	M-299	15 ft-lb MAX**	N/A	Adjust to leave one nut thickness of the threads exposed.
Inlet Ell	M-307	5 ft-lb	Thread Seal	
Cylinder Stud	M-277	5 ft-lb	Thread Lock	
Cylinder Stud & Jam Nut		15 ft-lb (Jam)	N/A	Tighten until the shock bushing swells to the washer diameter.
Crank Arm	M-289	28 ft-lb	N/A	Install the nut away from the housing.
Inlet Fittings	M-243	15 ft-lb	Thread Lock	
U-Bolt Nuts	M-251	28 ft-lb	Oil, torque evenly	Level the U-Bolt while torquing.
Jaw Bolt Nuts	M-251	15/18 ft-lb	N/A	
Cylinder Assembly		N/A	N/A	Remove the retaining ring & pull internals together with the rod end to disassemble.
Rod End	M-286	20 ft-lb	Thread Lock	Remove the seals, heat to 550°F to break the thread lock, and install new rod seal.

All parts must be completely clean and lubricated before assembly or rapid wear may result.

\*NOTE: Thread Seal: Non-hardening gasket cement (Permatex "Aviation Form-A-Gasket" or equal).

Thread Lock: Lubricating, anaerobic hardening thread locking compound (Loctite 271, "Stud-N-Bearing Mount", or equal).

\*\* (One lb. In. equals 1/12 of one lb. Ft.).

**REMEMBER TO:**

- Bolt the shaker down securely.
- Seal the shaker to the pedestal with non silicone elastic sealant.
- Provide a drainage hole beneath the shaker when bench top mounted.
- Mount the lubricator on a wall pipe or directly onto the shaker.
- Fill the lubricator bowl with air tool oil to the fill line.
- Keep the lubricator to shaker hose under 4 foot long. Avoid air line low spots (water traps).
- Install an air filter if there's water/dirt in the air line.
- Be sure the shaker gets enough air tool oil during operation.

## OPERATION

After installation, clamp the can firmly, but avoid crushing the can. Clamp mostly empty cans and aerosol cans with lid toward clamp handle. Tighten square gallons securely with the can lid straight up, the long sides of the can against the clamp jaws, and the corners resting on the jaw cradles.

**During operation, stay near the shaker while shaking square gallon or aerosol cans to ensure they do not leak or become loose. Aerosol cans only require a short shake time to loosen the internal agitation ball.**

Start and stop the shaker by quickly opening and closing the control valve (M-257) about 1/4 turn. If the shaker stops exactly at the center position or is not getting enough oil, it may not start automatically. Close the control valve and cock the can clamp to one side then open the control valve to re-start.

Check that the lubricators drip rate adjustment knob is set to 4. Adjust the lubricator by turning the vertical line on the drip rate dial clockwise until it stops and then turn it counter clockwise to number 4. Each time the shaker is started, the lubricator may take a few seconds to start dripping oil. A drip rate of once every 15 to 20 seconds is suitable. Do not force the adjustment knob or screw. If it is not working, check the oil level and see TROUBLESHOOTING on page 6.

Check the oil level once a week or more often as follows:

- Unscrew the lubricator bowl and dump any watery/milky oil out.
- Refill the oil to the level mark
- Carefully reinstall the bowl making sure the bowl gasket ring is in place and the bowl is screwed on straight.

- Check/adjust the shake angle if the air pressure at the shaker is over 120 PSI (780 kPa) with an air line at maximum normal pressure as follows:

- A) Clamp up a full one-gallon round can of paint
- B) Start the shaker
- C) Loosen the  $\frac{3}{8}$  inch lock nut at the adjustment screw on the air inlet fitting and adjust the screw to obtain a total shaking angle motion of about 30° (See below).
- D) Stop the shaker and tighten the lock nut while holding adjustment.

Use a non silicone spray lubricant to re-lubricate the clamp screw and grease for both Zerk fittings once every three months. (See below) Lubricate more often in severe duty, outdoor, and or dirty areas.

Grease the crank pin Zerk (one shot) through vent hole when can clamp is rotated left to stop. Use more air tool oil to avoid internal rust if you have heavy air line moisture, and install a filter. Check that the lubricator is oiling each time you stop shaker.

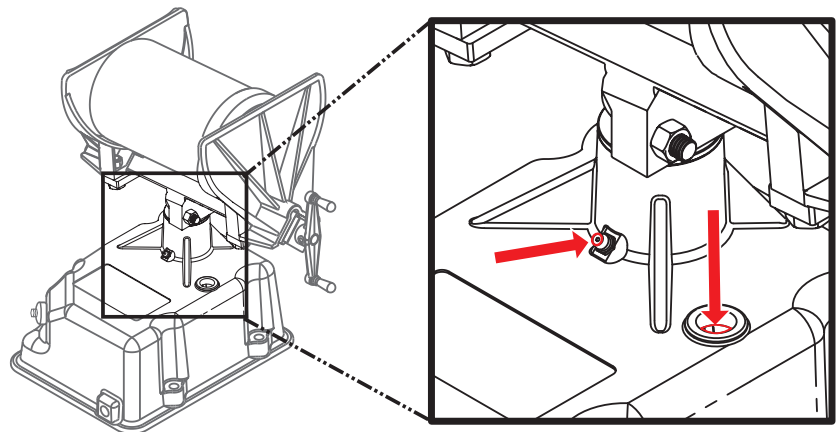
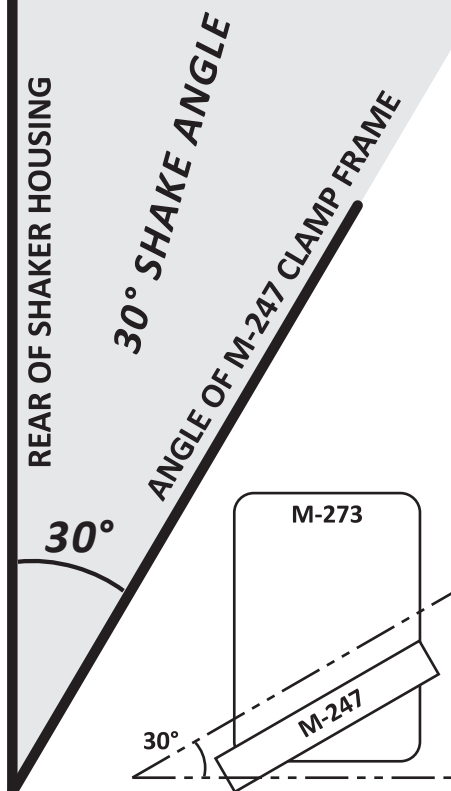

There are two Zerk fittings on the shaker that require multipurpose calcium or lithium-based chassis grease every three months. One is at the base of the main shaft on the main housing, the other is inside the main housing assembly. It can only be seen when the shaker is at a 30° angle. Rotate the shaker manually through a cycle until the Zerk fitting is visible for lubrication. The total angle is 30° when the Zerk fitting is just fully visible in the hole or, the total angle is 30° when the angle of the clamp frame (M-247) motion matches 30° angle shown to the left. The access hole in the top of the shaker housing should never have oil poured into it. It is only to allow access to the internal Zerk fitting to grease.



## SPECIFICATIONS

**Air Pressure:** 90 to 120 PSI (lbs./in<sup>2</sup> gage) (600 to 1200 kPa). Line pressure over 150 PSI requires a regulator and relief valve upstream of air hose.

**Air Inlet Threads:** ¼ inch PTF (Seal with thread tape).

**Shake Angle:** If operating at over 120 PSI pressure, the shake angle must be set to 30° (see page 4) with a full gallon can clamped, air at maximum normal line pressure. The shaker is supplied with a 30° shake angle. (See "OPERATION")

**Air Consumption:** Approximately 4.3 CFM (0.002 M3/sec) free air with 1 gallon (U.S.) 12 lb. can at 30° shake angle.

**Speed:** 135RPM to 800 RPM. Suggested at 700 cycles/minute at 30° shake angle. Adjustable at control valve, automatically compensates for can size.

**Capacity:** The shaker can hold half liter cans, and pint cans through four liter round cans. Including gallons, imperial gallons, most aerosols (with caps) and square gallons.

**Maximum Shake Weight:** The suggested maximum weight is 16 lbs. gross can weight.

**Recommended Shake Time:** Refer to your paint manufacturers recommendation.

**Final Filter:** Bronze, spring-retained 40 micron element behind inlet elbow (M-307).

**Oil Consumption:** Install the automatic lubricator and adjust the lubricator by the turning vertical line on the drip rate dial clockwise until it stops and then turn it counter clockwise to number 4. When not using the lubricator, add three drops of air tool oil at air inlet before every use. Allow a ten minute maximum operation time between manual oiling.

**Recommended Oil:** Petroleum 5W to 10W Non-detergent Rust Inhibiting Air Tool Oil such as Lubriplate Rockwell 10R. Oil should not contain gum removers or petroleum distillates. **Do not use motor oil.** Never use silicone oils or grease in a paint shop.

**Grease:** Multipurpose calcium or lithium-based chassis grease. Re-lubricate both Zerk fittings every 3 to 6 months, or more often in severe service.

Cyclone Air Shaker - Dedoes PN# 0910P  
20cm W x 26.5cm D x 35.5cm H (8in W x 10.5in D x 14in H)  
Weight: 9 kgs (20 lbs)

Pedestal - Dedoes PN# 0915P  
27cm W x 21cm D x 78cm H (10.75in W x 8.25in D x 30.75in H)  
Weight: 7 kgs (15 lbs)



## TROUBLESHOOTING

### **Issue: Shaker will not shake**

1. If it is newly installed, there is probably a blockage in the inlet fitting (M-243). The user may hear air blowing through the shaker without it shaking. It is possible that pipe tape may be causing blockage in the air supply. Disconnect the air hose (M-311) inside the shaker at the motor, and blow the blockage out through the inlet fitting. Blockage may cause the shaker to start and then stop, then restart and stop repeatedly as it sucks the blockage into the system at start up and blows it back out when it is shut off again.
2. If the shaker is two to three months old, check the lubrication. While the lubricator (M-318) is removed, squirt a few drops of air tool oil into the inlet fitting (M-243) and start the shaker. After a few cycles it should be operational. Reattach the lubricator and fill with oil. Ensure the correct installation of the lubricator. Adjust the lubricator by turning the vertical line on the drip rate dial clockwise until it stops and then turn it counter clockwise to number 4. The drip rate is preset prior to shipping, it should not have to be adjusted. Check the O-ring seal around the bowl, replace/adjust as needed.
3. If it is an older shaker, it may need to be rebuilt with a rebuild kit (M-232RK). Test to check the compression by moving the Can Clamp Assembly (M-315) back and forth to see if there is any resistance in the shake cycle. There should be resistance when moving the can clamp. If not, a rebuild kit is likely needed. Rebuild kits include instructions to replace seals, o-rings, and other vital components within the shaker. See page 9 for more information.
4. Check the screw (M-262) in the inlet fitting (M-243). It should not be turned down too far. One and a half threads should be visible when looking into the inlet fitting. Turning the screw too far will reduce the air supply and stop the shaker. The speed of the shaker can be adjusted by turning the inlet fitting screw.

### **Issue: Shaker will not shake after being rebuilt.**

1. The Can Clamp Assembly (M-315) must be installed onto the Main Shaft (M-270) for the shaker to operate correctly.
2. It is possible the Rebuild Kit (M-232RK) may have been installed incorrectly. Follow the included instructions and review each step.
3. Inspect the Check Valve Discs (M-296 & M-297) to ensure they are not stacked on top of each other. Adjust as necessary.

Note: The exhaust ports are designed to exhaust air, oil, water or whatever else is going through the shaker each time the piston cycles. It is working properly when doing so.

### **Issue: The shaker is noisy**

1. Check the Rod End Bearing (M-287). Rotate the Can Clamp Assembly (M-315) until the interior Zerk fitting (M-272) is visible. Add lubrication to the Zerk Fitting in the Housing Assembly's (M-273) hole. Inspect and replace the Rod End Bearing as necessary.
2. Check the Clamp Nuts (M-250 & M-254). Paint build up on the Clamp Frame (M-247) over time can cause these to loosen from the Clamp Screw (M-253) and the Jaws (M-244). Clean the Clamp Frame of paint buildup and replace/re-tighten the Clamp Nuts as necessary.
3. Seal or reseal the shaker to the Pedestal or bench top. Sealing the shaker to its mounting surface will prevent 60% of operation noises.
4. Check the Shock Bushing (M-263). Cans that are too heavy (+16 lbs) can cause premature wear on the Shock Bushing. Also, too much air pressure (+150 lbs.) can cause wear. Inspect and replace the Shock Bushing as necessary.

### **Issue: Smoke/Vapor coming out of the lubrication hole in the Housing Assembly (M-273) or oil leaking out of the base of the shaker.**

1. The lubricator (M-318) maybe set too high. Adjust the lubricator by turning the vertical line on the drip rate dial clockwise until it stops and then turn it counter clockwise to number 4. Seal the shaker to the pedestal or bench top to reduce leaking.

### **Issue: Broken U-bolt (M-252)**

1. The nuts (M-251) have been over tightened when the angle of the can clamp has been adjusted. The nuts should have 28 pounds of torque evenly spread between them.

### **Issue: User hears air blowing through an older shaker but it does not shake.**

1. Check the Piston O-ring (M-265) and the Check Valves (M-296 and/or M-297). Clean and replace as necessary.



## TROUBLESHOOTING

### **Issue: Jaws not staying tight on the paint cans.**

1. Paint build up on the Clamp Frame (M-247) may cause the Clamp Nuts (M-250 and/or M-254) to become worn or loose when forcing the Jaws (M-244) closed. Clean and inspect the Clamp Frame and replace/re-tighten the Clamp Nuts as necessary.

### **Issue: The shake angle is too large**

1. The can may be over the maximum of 16 lbs or may have catalyzed solid. Inspect and replace the can.
2. The shaker is receiving too much air pressure. Adjust the control valve (M-257). Line pressure over 150 PSI requires regulator and relief valve upstream of air hose.
3. The shake angle at start up should be adjusted to 30° (See page 4). The shaker is supplied from the manufacturer with a 30° shake angle.

### **Issue: The shaker runs slow and or stops**

1. Check the oil. It may be out of oil or fouled with motor oil. Refill and replace the oil as necessary.
2. The shaker is not getting enough air. Check for any of the following causes. The air pressure is low. The air supply is being restricted. The inlet filter (M-305) / inlet fitting (M-242) is blocked. The inlet screw (M-262) is set too low. Adjust the screw until one and a half threads are visible within the opening.
3. The relief valve is stuck open or the final filter is clogged.
4. The valve discs are dirty, seals are missing or damaged, or the piston o-ring (M-265) is worn.

### **Issue: The shaker is hard starting**

1. When the compression is OK and the motor moves freely check for bad piston seals, a dirty disc in valve body, air contamination residue, or excess water. It may also be that the shaker is being turned on too slowly, or that the angle adjustment screw (M-262) on the inlet fitting (M-242) is turned in too far.
2. When the compression is OK, but the motor is dragging, it is likely due to not enough air oil, or the improper type of oil.
3. With very low compression, but the motor moves freely, check the piston (M-280), and the piston o-ring (M-265) for damage. There also may not be enough oil to seal valve discs, or a stuck relief valve.

### **Issue: Lubricator will not operate**

1. Check the oil in the lubricator (M-318), fill as necessary. Check to make sure the adjustment knob is open and set to 4 and that the flow arrow on the lubricator is pointing toward the shaker.
2. Vibration during operation may be preventing drip visibility when mounted onto shaker.
3. Check the bowl of the lubricator for damage, missing gaskets and o-rings, or damaged/crossed threads.

### **Issue: The shaker uses too much air**

1. The shake angle is too large. Adjust it to 30°.
2. Check the relief valve, it may be stuck or broken. Also inspect the piston seals or rod seal (M-282) and replace as necessary.

### **Issue: The shaker is leaking oil**

1. The shaker housing is not sealed to a pedestal or bench. Apply sealant all around the bottom of the housing and the bolt holes. Seal the shaker to its mounting surface to reduce the majority of operation noise.
2. The lubricator (M-318) dial is opened too much. Adjust the lubricator by turning the vertical line on the drip rate dial clockwise until it stops and then turn it counter clockwise to number 4.



It is recommended to grease/lubricate the Cyclone Shaker every three months and check the oil once a week.  
Use Non detergent Air Tool Oil 5W to 10W to refill the Cyclone Shaker.

			Oil		Grease	
Date	Completed By	Verified By	Okay	Added	Okay	Added





# Cyclone Paint Shaker User Manual

Part No: 0910P (Shaker) / 0915P (Pedestal)



Part no.	Description	Part no.	Description		
M-232RK	<b>Shaker Repair Kit</b>	M-274	Crank Arm Bolt		
	Includes: (1) M-296, (1) M-297, (1) M-298, (1) M-305, (2) M-310, (1) M-311, (1) M-263, (1) M-264, (1) M-265, (1) M-266, (2) M-293	M-275	Bolt Bushing		
		M-276	Crank Arm Nut		
M-243	<b>Inlet Fitting Assembly</b>	M-277	Cylinder Stud		
	Includes: (1) M-262, (1) M-261, (1) M-260, (1) M-242	M-278	Cylinder Body		
M-252K	<b>U Bolt Kit</b>	Includes: (1) M-252, (2) M-251	M-279	Piston Screw	
M-273	<b>Housing Assembly</b>	M-280	Piston		
	Includes: (2) M-271, (1) M-272, (1) M-243	M-281	Rod Bearing		
M-284	<b>Front Cylinder Head Assembly</b>	M-282	Rod Seal		
	Includes: (1) M-281, (1) M-282, (1) M-283, (1) M-266	M-283	Cylinder Head		
M-288	<b>Cylinder Internal Assembly</b>	M-285	Cylinder Rod		
	Includes: (1) M-284, (1) M-279, (1) M-280, (1) M-264, (1) M-265, (1) M-267, (1) M-285, (1) M-286, (1) M-287	M-286	Rod End		
		M-287	Rod End Bearing		
M-295	<b>Inlet Valve Body Assembly</b>	M-289	Crank Arm		
	Includes: (1) M-294, (1) M-298, (1) M-297, (1) M-296	M-290	Crank Pin		
M-304	<b>Outer Valve Body Assembly</b>	M-291	Crank Thrust Washer		
	Includes: (1) M-307, (1) M-06, (1) M-305, (1) M-309, (1) M-303. (1) M-302, (1) M-301, (1) M-300, (1) M-299	M-292	Crank Pin Retaining Ring		
		M-293	Transfer O-Ring		
M-315	<b>Can Clamp Assembly</b>	M-294	Inlet Valve Body		
	Includes: (2) M-244, (6) M-251, (1) M-252, (4) M-255, (1) M-253, (1) M-247, (1) M-250, (1) M-249, (1) M-248, (1) M-246, (1) M-245	M-296	Check Valve Disc		
		M-297	Valve Disc		
M-316	<b>Cylinder Motor Assembly</b>	M-298	Valve Body O-Ring		
	Includes: (1) M-288, (1) M-277, (2) M-293, (1) M-278, (3) M-308	M-299	Relief Jam Nut		
M-317	<b>Motor with Crank Arm</b>	M-300	Relief Set Screw		
	Includes: (1) M-295, (1) M-304, (1) M-316, (1) M-274, (2) M-275, (1) M-276, (1) M-289, (1) M-272, (2) M-292, (2) M-291, (1) M-290	M-301	Relief Spring		
		M-302	Relief Ball		
M-240	Brass Close Nipple	M-255	Jaw Bolt	M-303	Outer Valve Body
M-242	Inlet Fitting	M-257	Control Valve	M-305	Inlet Filter
M-244	Jaw	M-260	Adjustable Seal	M-306	Filter Spring
M-245	Roll Pin	M-261	Adjustable Jam Nut	M-307	Inlet Elbow
M-246	Handle	M-262	Adjustable Screw	M-308	Valve Body Screw
M-247	Clamp Frame Weld	M-263	Shock Mount Bushing (4 pieces)	M-309	Transfer Plug
M-248	Thrust Washer	M-264	Wear Ring	M-310	Hose Clamp
M-249	Screw Retaining Ring	M-265	Piston O-Ring	M-311	Air Hose
M-250	Clamp Nut - Left Hand	M-266	Head O-Ring	M-312	User Manual
M-251	3/8-16 Nut	M-267	Head Retaining Ring	M-313	Housing Bolt
M-252	U-Bolt	M-268	Main Thrust Washer	M-314	Drain Fitting
M-252K	U-Bolt Kit	M-270	Main Shaft	M-318	Automatic Lubricator
M-253	Clamp Screw	M-271	Main Bearing	0910P	Complete Cyclone Shaker
M-254	Clamp Nut - Right Hand	M-272	Zerk Fitting	0915P	Complete Pedestal

For technical support on our products or additional accessories, please call us at 248-624-7710 or visit our web site: [www.dedoes.com](http://www.dedoes.com)

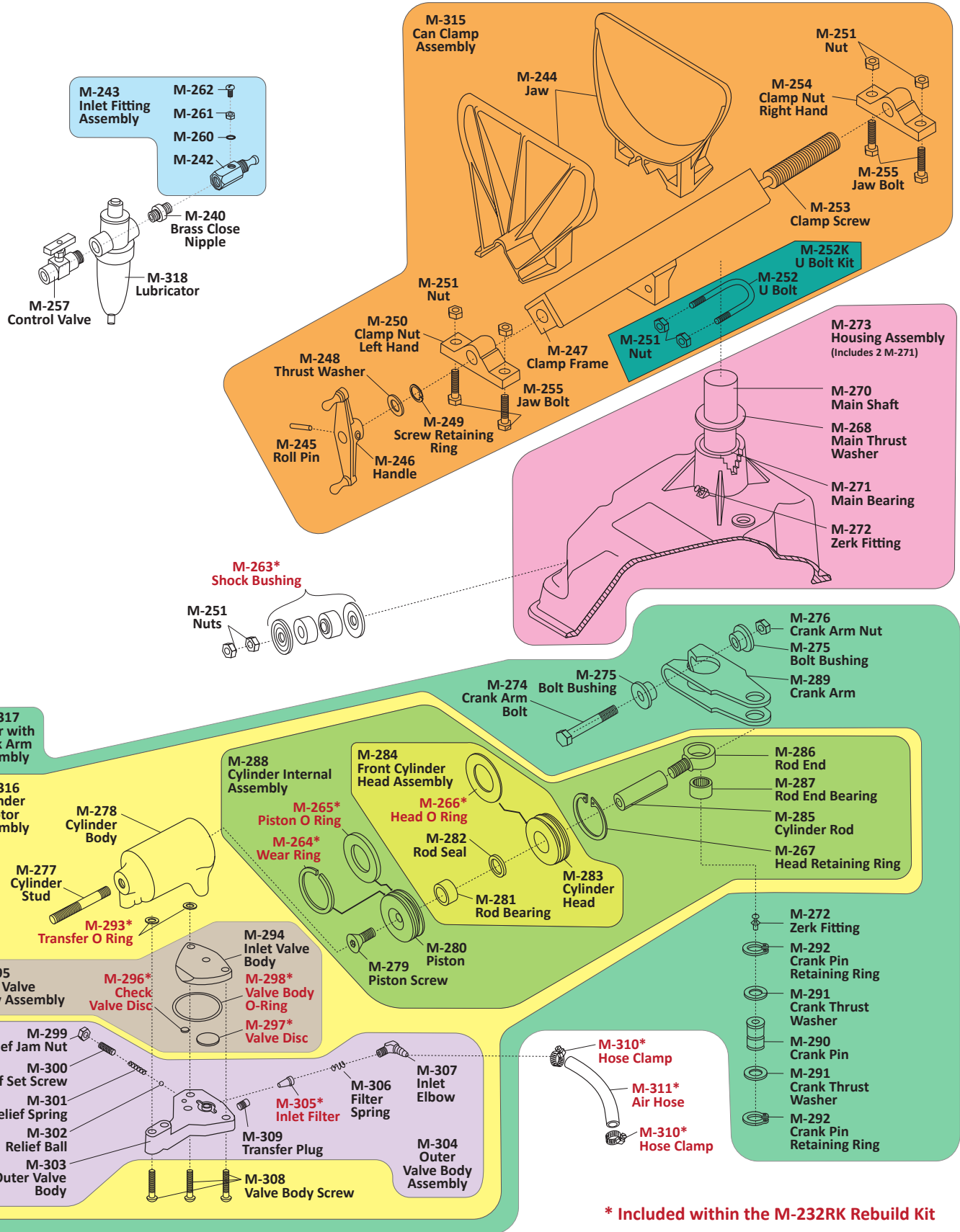

# PEDESTAL TO FLOOR TEMPLATE

7.0 INCH  
178 MILLIMETERS

7.0 INCH  
178 MILLIMETERS

7.0 INCH  
178 MILLIMETERS

7.0 INCH  
178 MILLIMETERS

**The Pedestal includes six interior holes to mount to a wheel and tire if desired. DO NOT use these holes to mount the Pedestal to the floor, damage will result. Use the outer holes in Pedestal base to mount it to the floor.**

The Pedestal base is 8.0 inch (203 mm) square.

Each mounting hole is at a 0.5 inch (12.5 mm) from outer edges.

The recommended bolt length for mounting the pedestal is 1.5 inch (38 mm) to 2.0 inch (51 mm) minimum.

Drill four holes in the floor and install the pedestal with expansion bolt anchors and  $\frac{3}{8}$  inch (10 mm) machine bolts.

The inner circles on the template are intended to assist with mounting the pedestal to a wheel and tire.

Remember to seal the shaker to the pedestal with a non silicone elastic sealant to prevent leaks and reduce noise.

# SHAKER TO BENCH TEMPLATE

IT IS HIGHLY RECOMMENDED TO MOUNT THE SHAKER TO THE OPTIONAL PEDESTAL AND SECURE THE PEDESTAL TO THE FLOOR.

The shaker base is 8.0 inch (203 mm) by 10.5 inch (267 mm).

Drill five  $\frac{1}{8}$  inch (11 mm) holes in the surface and install the shaker using  $\frac{3}{8}$  inch (10 mm) machine bolts.

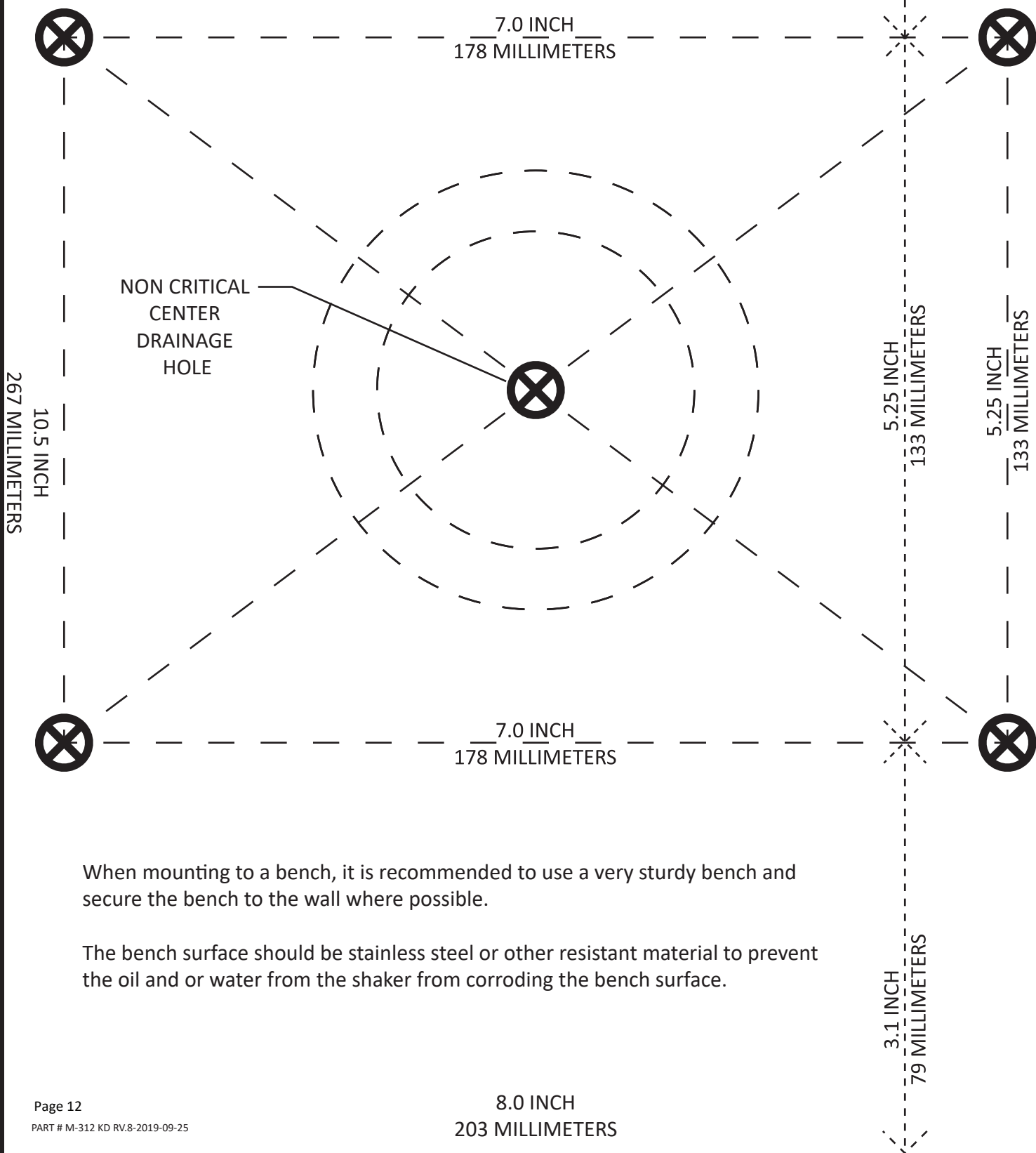

When mounting to a bench, it is recommended to use a very sturdy bench and secure the bench to the wall where possible.

The bench surface should be stainless steel or other resistant material to prevent the oil and or water from the shaker from corroding the bench surface.